



FORMIKE ELECTRONIC CO.,LTD

PRDUCT SPECIFICATON

TFT LCD MODULE

MODEL : KWH032GM02-F05

【 】 Preliminary Specification

【 ♦ 】 Finally Specification

| CUSTOMER'S APPROVAL | |
|---------------------|-------|
| SIGNATURE: | DATE: |
| | |

| APPROVED BY | PM REVIEWD | PD REVIEWD | PREPARED BY |
|-------------|------------|--------------|-------------|
| Wayne | Li tong | Zhengjinrong | Jully |

Prepared By :

FORMIKE ELECTRONIC CO.,LTD

Address : A909, Huaying Building, 97 Nanshang Road,Nanshan District, Shenzhen, China.518054

TEL:(86) 755 88306921,88306931 FAX:(86) 755 88304615

Http:// www.wandisplay.com

- This specification is subject to change withouth notice.Please contact FORMIKE or it's representative before designing your product based on this specification.



TABLE OF CONTENTS

| | |
|--|----|
| 1. GENERAL DESCRIPTION | 2 |
| 2. FEATURES | 2 |
| 3. MECHANICAL SPECIFICATION..... | 2 |
| 4. MECHANICAL DIMENSION | 3 |
| 5. MAXIMUM RATINGS..... | 4 |
| 6. PIN ASSIGNMENT..... | 5 |
| 7. ELECTRICAL CHARACTERISTICS..... | 13 |
| 8. ELECTRO-OPTICAL CHARACTERISTICS | 17 |
| 9. RELIABILITY | 18 |
| 10. ROHS COMPLIANT WARRANTY..... | 19 |
| 11. PRECAUTIONS FOR USE | 19 |



1. GENERAL DESCRIPTION

KWH032GM02-F05 is a Transmissive type color active matrix liquid crystal display (LCD), which uses amorphous thin film transistor (TFT) as switching devices. This product is composed of a TFT LCD panel, driver IC, FPC, Backlight and Touch screen. The following table described the features of KWH032GM02-F05

2. FEATURES

| | |
|-------------------------|---|
| Display Mode | TFT LCD, Normally white, Transmissive Type, |
| Color Pixel Arrangement | RGB vertical Strip |
| Driver IC. | SPFD5408 |
| Number of colors | 262K color |
| Interface | MPU I/F(8/9/16/18 bit) , RGB I/F (18 bit) |
| Viewing Direction | 9 O'clock |

3. MECHANICAL SPECIFICATION

| Item | Specifications | Unit |
|---------------------|---------------------------|------|
| Dimensional outline | 55.94(H)×77.6(V)×4.5(T)* | Mm |
| Number of Pixels | 240(H)× 3(R,G,B) × 320(V) | Dot |
| Pixel Pitch | 0.2025(H) × 0.2025(V) | Mm |
| Active area | 48.6(H)×64.8(V) | Mm |

*note : This isn't include FPC.



5. MAXIMUM RATINGS

| ITEM | SYMBOL | MIN. | MAX. | UNIT | NOTE |
|-----------------------|-----------------|------|------|------|------|
| Operation Temperature | T _{OP} | -20 | 70 | | |
| Storage Temperature | T _{ST} | -30 | 80 | | |
| Power supply voltage1 | VCC, IOVCC | -0.3 | +4.6 | V | |

Formike Electronic Co., Ltd.



6. Pin Assignment

| Pin NO. | Symbol | Description |
|---------|--------|--|
| 1 | IM0 | Select a mode to interface to an MPU. |
| 2 | IM1 | In serial interface operation, the IM0 pin is used to set the ID bit of device code. |
| 3 | IM2 | Please refer to Note 1 for detail information |
| 4 | IM3 | |
| 5 | RESET | RESET pin. This is an active low signal. |
| 6 | VSYNC | In external interface mode, served as a vertical synchronize signal input. Must connect to the IOVCC or GND level when not in use. |
| 7 | HSYSC | In external interface mode, served as a horizontal synchronized signal input. Must connect to the IOVCC or GND level when not used. |
| 8 | DOTCLK | In external interface mode, served as a dot clock signal. When DPL = "0": Input data on the rising edge of DOTCLK When DPL = "1": Input data on the falling edge of DOTCLK It is fixed to the IOVCC level when not in use. |
| 9 | ENABLE | In external interface mode, polarity of ENABLE signal is synchronized with valid graphic data input. Low: Valid data on DB17-DB0 High: Invalid data on DB17-DB0 Moreover, setting EPL bit can change the polarity of the ENABLE signal. Must connect to the GND or IOVCC level when not in use. |
| 10 | DB17 | Served as an 18-bit parallel bi-directional data bus. Data bus pin assignment corresponding to different modes are summarized in the table: |
| 11 | DB16 | |
| 12 | DB15 | |
| 13 | DB14 | |
| 14 | DB13 | |



| 15 | DB12 | <table border="1"> <thead> <tr> <th>Mode</th> <th>Pin Assignment</th> </tr> </thead> <tbody> <tr> <td>8-bit system interface</td> <td>DB17-DB10</td> </tr> <tr> <td>9-bit system interface</td> <td>DB17-DB9</td> </tr> <tr> <td>16-bit system interface</td> <td>DB17-DB10, DB8-DB1</td> </tr> <tr> <td>18-bit system interface</td> <td>DB17-DB0</td> </tr> <tr> <td>6-bit External (RGB) interface</td> <td>DB17-DB12</td> </tr> <tr> <td>16-bit External (RGB) interface</td> <td>DB17-13, DB11-DB1</td> </tr> <tr> <td>18-bit External (RGB) interface</td> <td>DB17-DB0</td> </tr> </tbody> </table> | Mode | Pin Assignment | 8-bit system interface | DB17-DB10 | 9-bit system interface | DB17-DB9 | 16-bit system interface | DB17-DB10, DB8-DB1 | 18-bit system interface | DB17-DB0 | 6-bit External (RGB) interface | DB17-DB12 | 16-bit External (RGB) interface | DB17-13, DB11-DB1 | 18-bit External (RGB) interface | DB17-DB0 |
|---------------------------------|--------------------|--|------|----------------|------------------------|-----------|------------------------|----------|-------------------------|--------------------|-------------------------|----------|--------------------------------|-----------|---------------------------------|-------------------|---------------------------------|----------|
| Mode | Pin Assignment | | | | | | | | | | | | | | | | | |
| 8-bit system interface | DB17-DB10 | | | | | | | | | | | | | | | | | |
| 9-bit system interface | DB17-DB9 | | | | | | | | | | | | | | | | | |
| 16-bit system interface | DB17-DB10, DB8-DB1 | | | | | | | | | | | | | | | | | |
| 18-bit system interface | DB17-DB0 | | | | | | | | | | | | | | | | | |
| 6-bit External (RGB) interface | DB17-DB12 | | | | | | | | | | | | | | | | | |
| 16-bit External (RGB) interface | DB17-13, DB11-DB1 | | | | | | | | | | | | | | | | | |
| 18-bit External (RGB) interface | DB17-DB0 | | | | | | | | | | | | | | | | | |
| 16 | DB11 | | | | | | | | | | | | | | | | | |
| 17 | DB10 | | | | | | | | | | | | | | | | | |
| 18 | DB9 | | | | | | | | | | | | | | | | | |
| 19 | DB8 | | | | | | | | | | | | | | | | | |
| 20 | DB7 | | | | | | | | | | | | | | | | | |
| 21 | DB6 | | | | | | | | | | | | | | | | | |
| 22 | DB5 | <p>Must connect to the GND or IOVCC level when not in use.</p> <p>Please refer to Note2 for detail information.</p> | | | | | | | | | | | | | | | | |
| 23 | DB4 | | | | | | | | | | | | | | | | | |
| 24 | DB3 | | | | | | | | | | | | | | | | | |
| 25 | DB2 | | | | | | | | | | | | | | | | | |
| 26 | DB1 | | | | | | | | | | | | | | | | | |
| 27 | DB0 | | | | | | | | | | | | | | | | | |
| 28 | SDO | Series Data is the output on the rising edge of the SCL signal in SPI mode. | | | | | | | | | | | | | | | | |
| 29 | SDI | Series Data is the input on the rising edge of the SCL signal in SPI mode. Must connect to the GND or IOVCC level when not in use. | | | | | | | | | | | | | | | | |
| 30 | RD | In 80-system interface mode, a read strobe signal can be input via this pin and initializes a read operation when the signal is low. Must connect to the GND or IOVCC level when not in use. | | | | | | | | | | | | | | | | |
| 31 | WR | (A) In 80-system interface mode, a write strobe signal can be input via this pin and initializes a write operation when the signal is low. (B) In SPI mode, served as a synchronizing clock signal. | | | | | | | | | | | | | | | | |



| | | |
|----|--------|--|
| 32 | RS | <p>Register select signal. Low: Index register or internal status is selected. High: Control register is selected. Must connect to the GND or IOVCC level when not used.</p> <p>This pin has weak pull high/low resistors and can be modified to high / low by metal layer change for customer's request.</p> |
| 33 | CS | <p>Chip select signal. Low: the LCD module is accessible High: the LCD module is not accessible Must connect to the GND or IOVCC level when not used. This pin has weak pull high/low resistors and can be modified to high / low by metal layer change for customer's request.</p> |
| 34 | VCC | <p>Internal logic power: VCC = 2.5V ~3.3V. VCC ≥ IOVCC.</p> |
| 35 | IOVCC | <p>Power supply to the interface pins: RESET*, CS*, WR, RD*, RS, DB17-0, VSYNC, HSYNC, DOTCLK, ENABLE. IOVCC = 1.65V ~ 3.3V. VCC ≥ IOVCC.</p> |
| 36 | GND | Power Ground |
| 37 | LED A5 | Anode of backlight diode |
| 38 | LED A4 | Anode of backlight diode |
| 39 | LED A3 | Anode of backlight diode |
| 40 | LED A2 | Anode of backlight diode |
| 41 | LED A1 | Anode of backlight diode |
| 42 | LED K | Cathode of backlight diode |
| 43 | X1 | Touch screen interface (Right) |
| 44 | X2 | Touch screen interface (Left) |
| 45 | Y1 | Touch screen interface (Top) |
| 46 | Y2 | Touch screen interface (Bottom) |



Select a mode to interface to an MPU. In serial interface operation, the IM0 pin is used to set the ID bit of device code.

| IM3 | IM2 | IM1 | IM0/ ID | Interface Mode | DB Pin | Colors |
|-----|-----|-----|------------|------------------------------------|----------------|--------------------|
| 0 | 0 | 0 | 0 | Setting disabled | - | - |
| 0 | 0 | 0 | 1 | Setting disabled | - | - |
| 0 | 0 | 1 | 0 | 80-system 16-bit interface | DB17-10, DB8-1 | 262,144 see Note 1 |
| 0 | 0 | 1 | 1 | 80-system 8-bit interface | DB17-10 | 262,144 see Note 2 |
| 0 | 1 | 0 | *(ID) | Clock synchronous serial interface | - | 65,536 |
| 0 | 1 | 1 | 0 | Setting disabled | - | - |
| 0 | 1 | 1 | 1 | Setting disabled | - | - |
| 1 | 0 | 0 | 0 | Setting disabled | - | - |
| 1 | 0 | 0 | 1 | Setting disabled | - | - |
| 1 | 0 | 1 | 0 | 80-system 18-bit interface | DB17-0 | 262,144 |
| 1 | 0 | 1 | 1 | 80-system 9-bit interface | DB17-9 | 262,144 |
| 1 | 1 | 0 | 0 | Setting disabled | - | - |
| 1 | 1 | 0 | 1 | Setting disabled | - | - |
| 1 | 1 | 1 | 0 | Setting disabled | - | - |
| 1 | 1 | 1 | 1 | Setting disabled | - | - |

Note2:

Notes: 1. 65,536 colors in one transfer mode
2. 65,536 colors in two transfers mode

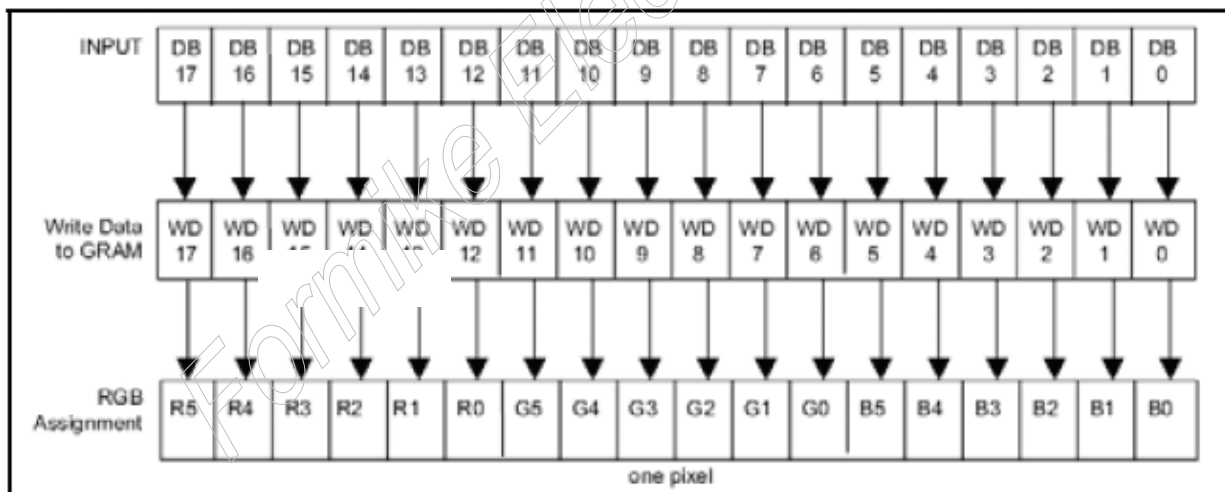

Figure 6-8 18-bit interface (262,144 colors)

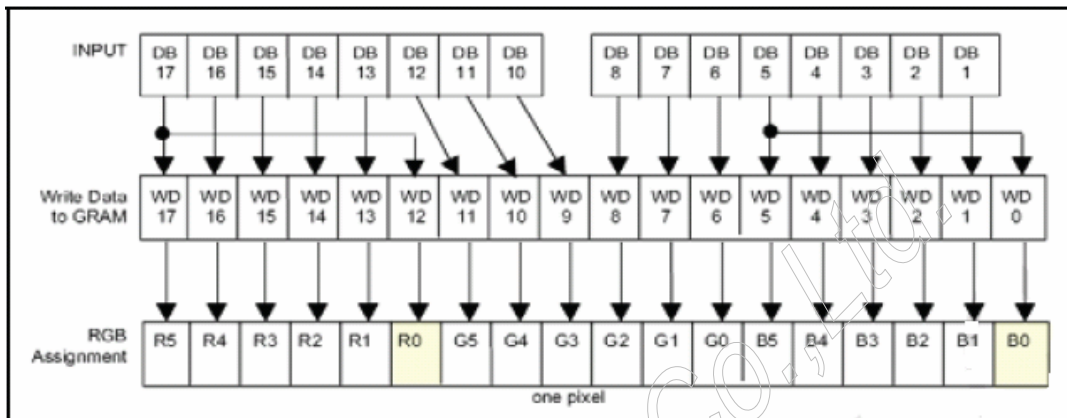

Figure 6-9 16-bit interface (65,536 colors) TRIREG= 0

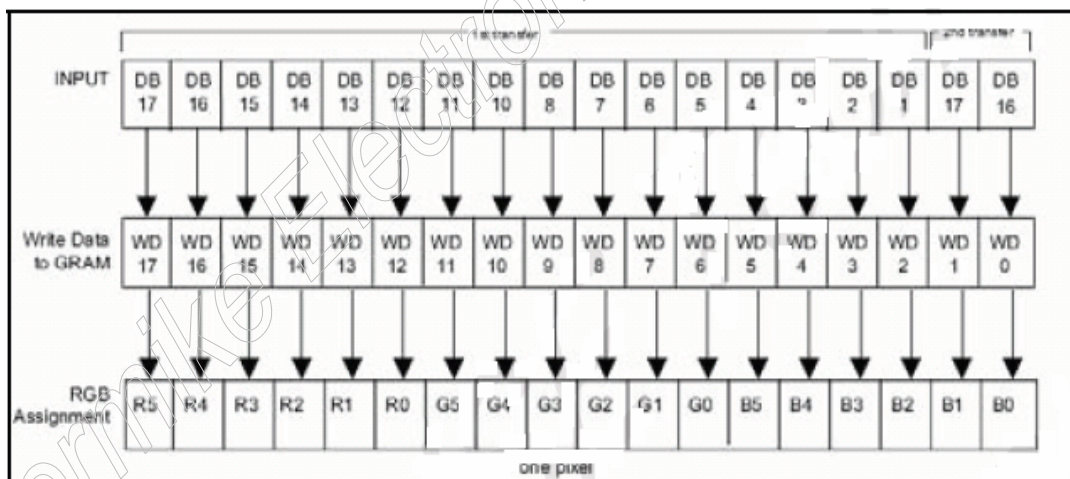

Figure 6-10 16-bit interface (262,144 colors) TRIREG = 1, DFM = 0

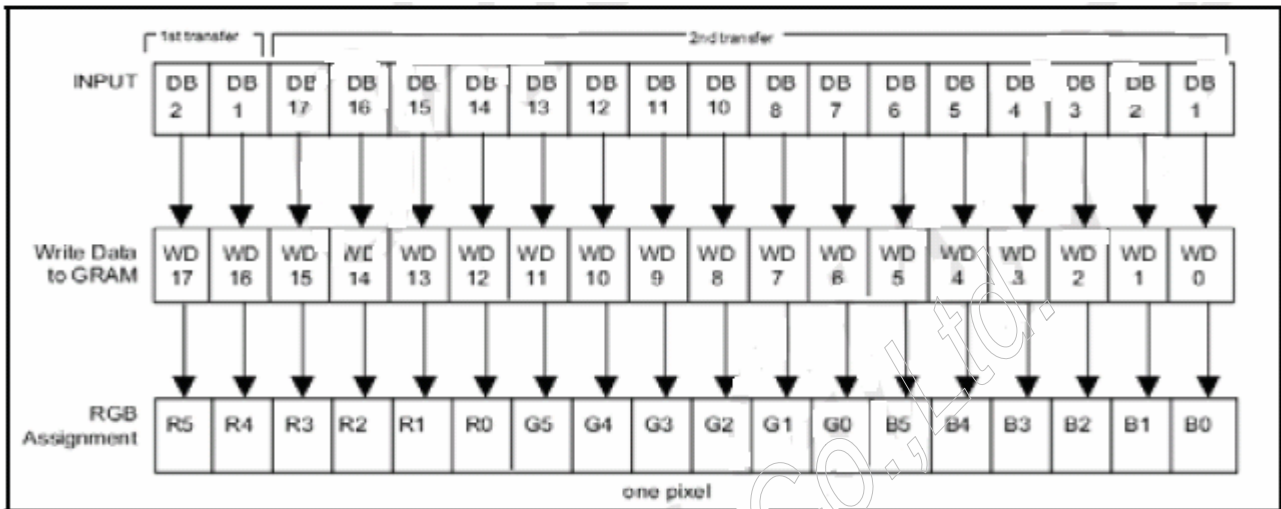

Figure 6-11 16-bit interface (262,144 colors) TRIREG = 1, DFM = 1

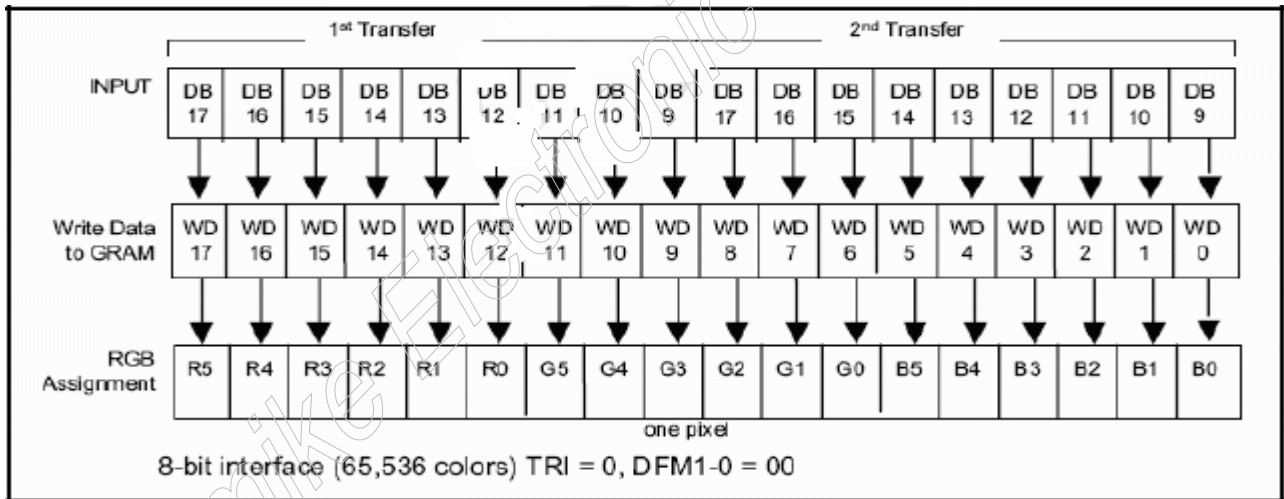

Figure 6-12 9-bit interface (262,144 colors) TRI = 0, DFM1-0 = 00

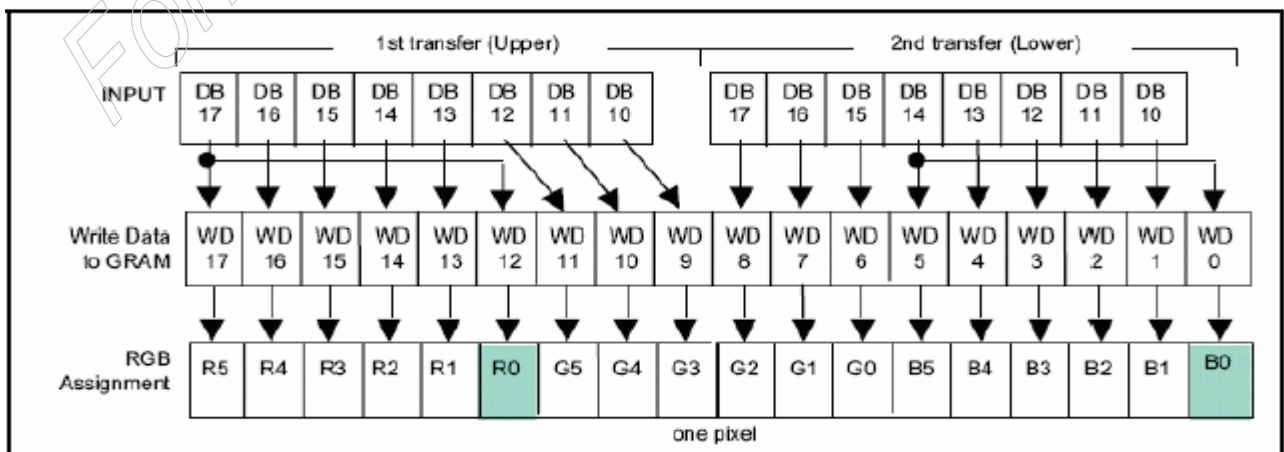

Figure 6-13 8-bit interface (65,536 colors) TRIREG = 0

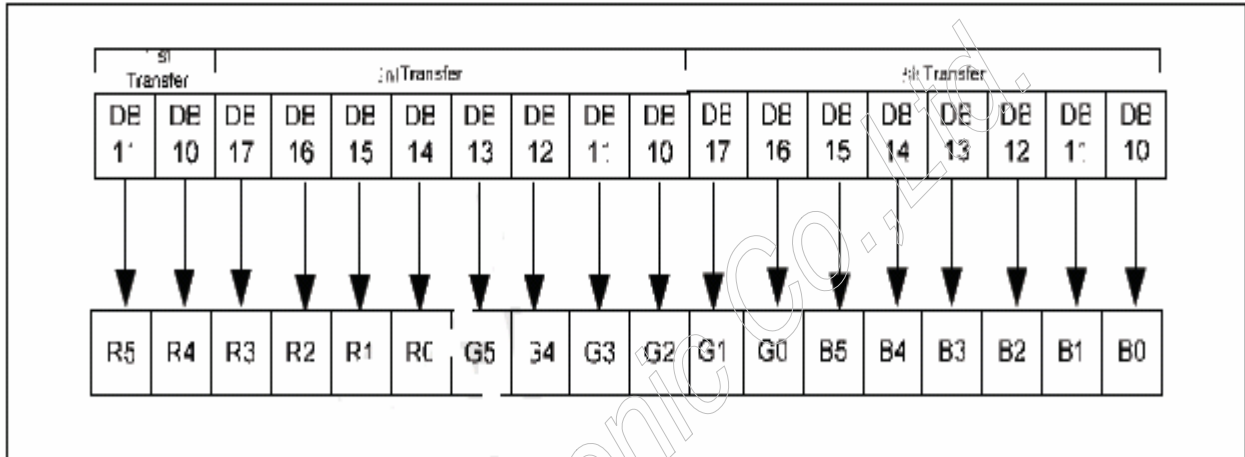

Figure 6-14 8-bit interface (262 colors) TRIREG = 1, DFM=0.

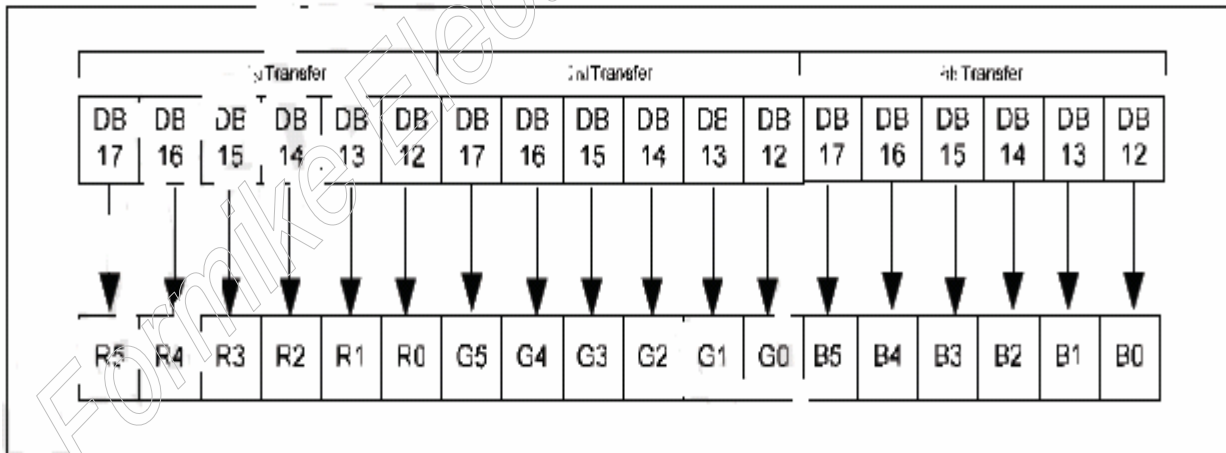
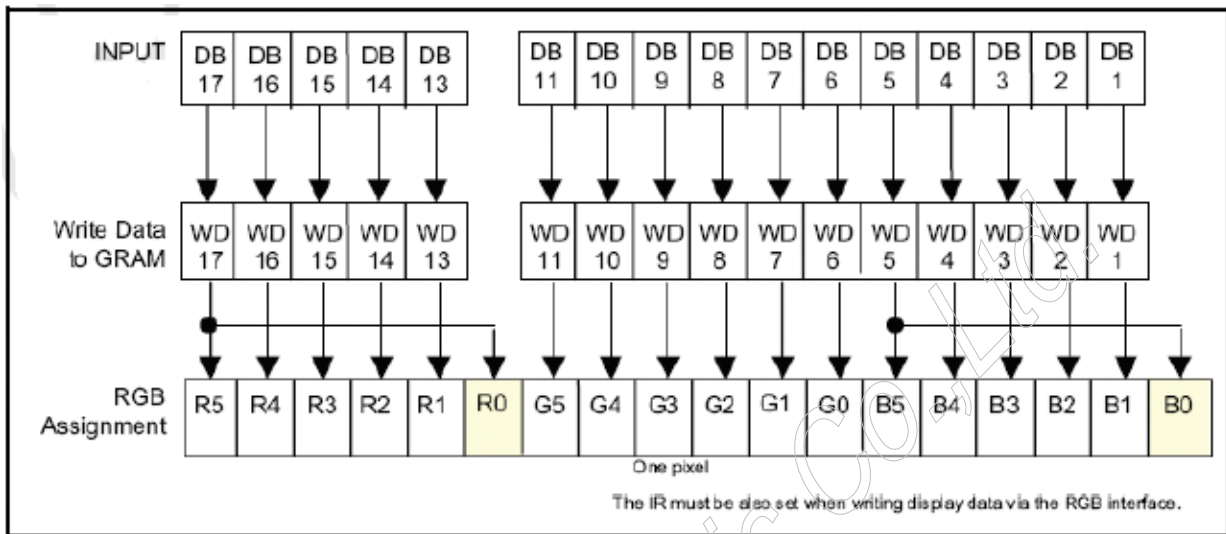
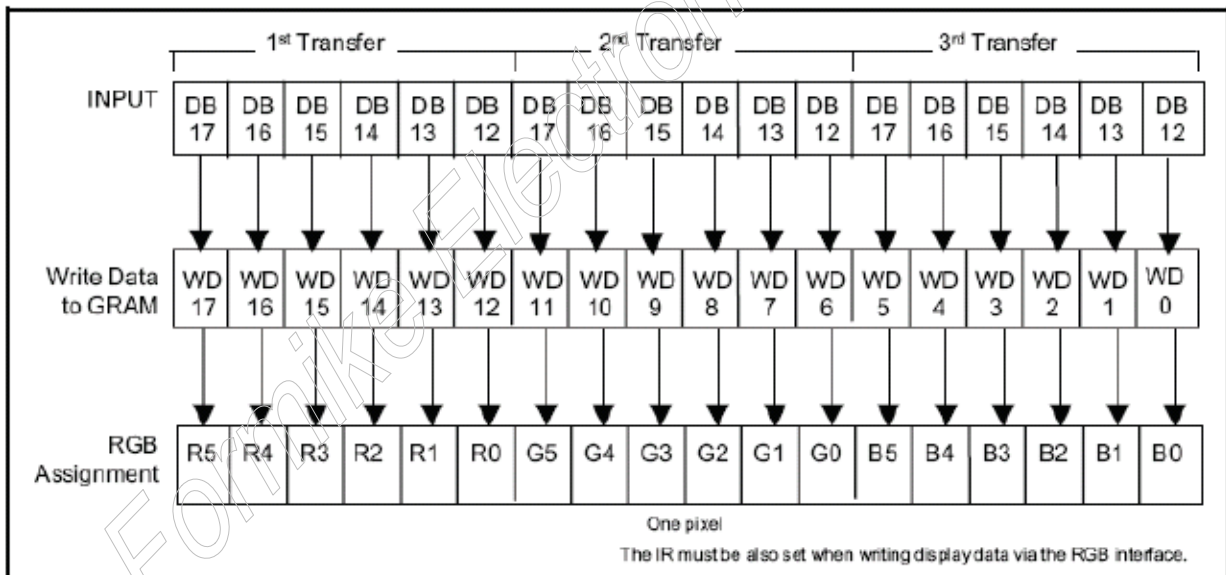

Figure 6-15 8-bit interface (262K colors) TRIREG = 1, DFM=1



16-bit RGB interface (65,563 colors)



6-bit RGB interface (262,144 colors)



7. ELECTRICAL CHARACTERISTICS

7.1.LCM DC CHARACETRISTIC

Typical operating conditions

(GND=AVSS=0V)

| Item | Symbol | Min. | Typ. | Max. | Unit | Note |
|------------------------------|-----------|----------|-------------------|------|-------------------|------|
| Power supply | VCC | 2.5 | - | 3.3 | V | |
| | IOVCC | 1.65 | - | 3.3 | | |
| Driver Input signal voltage | H | V_{IH} | $0.8 \cdot IOVCC$ | - | IOVCC | V |
| | L | V_{IL} | GND | - | $0.2 \cdot IOVCC$ | V |
| Driver output signal voltage | H | V_{OH} | $0.8 \cdot IOVCC$ | - | - | V |
| | L | V_{OL} | - | - | $0.2 \cdot IOVCC$ | V |
| Power consumption | P_{LCD} | - | 30 | - | mW | *1 |

Note:

*1: Not include backlight.

7.2.BACKLIGHT CHARACETRISTIC

| Item | Symbol | Values | | | Unit | Remark |
|-------------------|-----------|--------|------|------|------|----------------|
| | | Min. | Typ. | Max. | | |
| Power Consumption | P | 288 | 330 | 450 | mW | Backlight unit |
| LED Current | I_{LED} | 18 | 20 | 25 | mA | Single LED |
| LED Voltage | V_{LED} | 3.2 | 3.3 | 3.6 | V | Single LED |

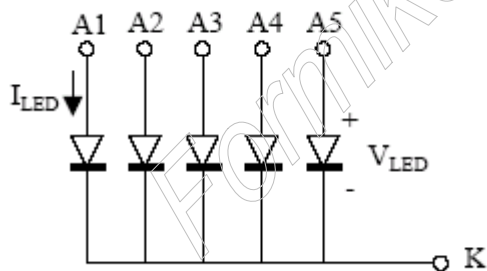



7.3.AC CHARACETRISTIC

A.80-system (18-bit / 16-bits) bus interface

Normal write operation (HWM=0 or 1), IOVCC=1.65V~3.30V

| Item | Symbol | Unit | Min. | Typ. | Max. |
|------------------------------|------------------------|-------|------|------|------|
| Bus cycle time | Write | tCYCW | ns | 125 | - |
| | Read | tCYCR | ns | 450 | - |
| Write low-level pulse width | PWLW | ns | 45 | - | - |
| Read low-level pulse width | PWLR | ns | 170 | - | - |
| Write high-level pulse width | PWHW | ns | 70 | - | - |
| Read high-level pulse width | PWHR | ns | 250 | - | - |
| Write/Read rise/fall time | tWRr, WRf | ns | - | - | 25 |
| Setup time | Write (RS to CS*, WR*) | tAS | ns | 0 | - |
| | Read (RS to CS*, RD*) | | ns | 10 | - |
| Address Hold Time | tAH | ns | 2 | - | - |
| Write data setup time | tDSW | ns | 25 | - | - |
| Write data hold time | tH | ns | 10 | - | - |
| Read data delay time | tDDR | ns | - | - | 150 |
| Read data hold time | tDHR | ns | 5 | - | - |

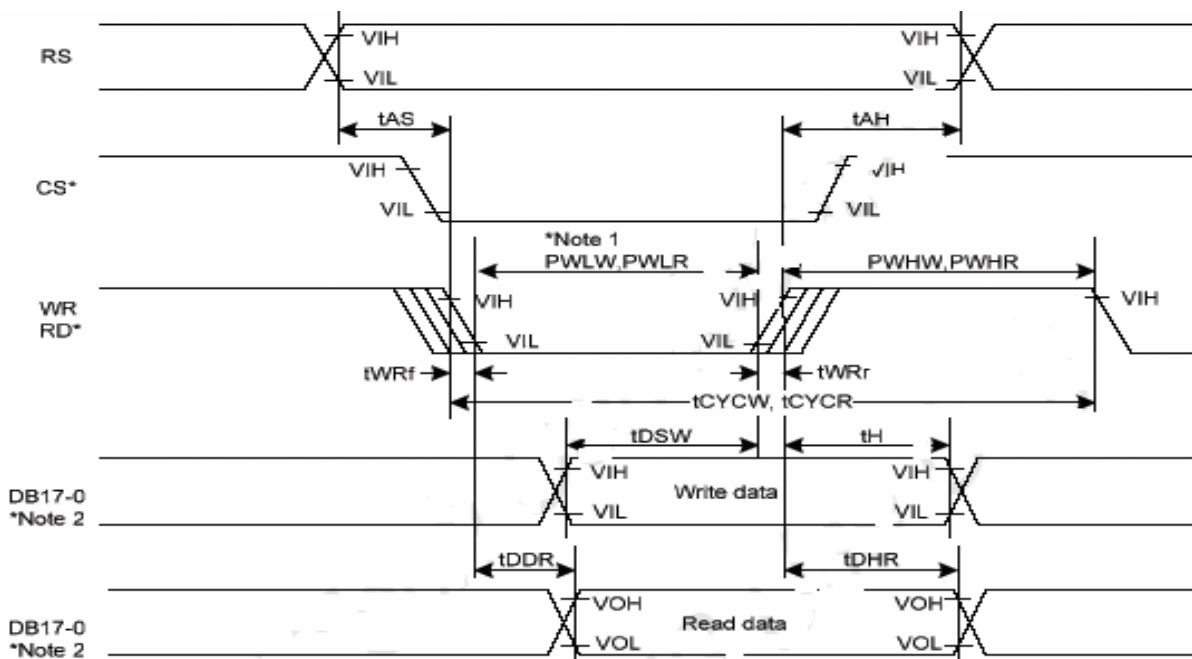

Note1: PWLW and PWLR are defined by the overlap period when CS is "Low" and WR* or RD* is "Low".
 *Note2: Unused DB pins must be fixed at "IOVcc 1" or "IOGND 1".



B. Clock-synchronized serial interface

Normal Write Function (HWM=0), High-speed Write Function (HWM=1), IOVCC=1.65~3.30V

| Item | Symbol | Unit | Min. | Typ. | Max. | |
|-------------------------------|--------------------|-------|------|------|------|--------|
| Serial Time Clock Cycle | Write (received) | tSCYC | ns | 100 | - | 20.000 |
| | Read (transmitted) | tSCYC | ns | 350 | - | 20.000 |
| Serial Clock high-level width | Write (received) | tSCH | ns | 40 | - | - |
| | Read (transmitted) | tSCH | ns | 150 | - | - |
| Serial Clock low-level width | Write (received) | tSCL | ns | 40 | - | - |
| | Read (transmitted) | tSCL | ns | 150 | - | - |
| Serial clock rise/fall time | tSCr, tSCf | ns | - | - | 20 | |
| Chip select setup time | tCSU | ns | 20 | - | - | |
| Chip select hold time | tCH | ns | 60 | - | - | |
| Serial input data setup time | tSISU | ns | 30 | - | - | |
| Serial input data hold time | tSIH | ns | 30 | - | - | |
| Serial output data delay time | tSOD | ns | - | - | 130 | |
| Serial output data hold time | tSOH | ns | 5 | - | - | |

C. RGB interface

18-/ 16- bit RGB interface (HWM=0 or 1), IOVCC=1.65~3.30V

| Item | Symbol | Unit | Min. | Typ. | Max. |
|--|----------------|-------|------|------|------|
| VSYNC/HSYNC Setup time | TSYNCS | clock | 0 | - | 1 |
| ENABLE Setup time | TENS | ns | 10 | - | - |
| ENABLE Hold time | TENH | ns | 20 | - | - |
| DOTCLK low-level pulse width | PWDL | ns | 40 | - | - |
| DOTCLK high-level pulse width | PWDH | ns | 40 | - | - |
| DOTCLK cycle time | TCYCD | ns | 100 | - | - |
| Data setup time | TPDS | ns | 10 | - | - |
| Data hold time | TPDH | ns | 40 | - | - |
| DOTCLK, VSYNC and HSYNC rise/fall time | Trgbr Trgbf | ns | - | - | 25 |

6-bit RGB interface (HWM=0 or 1), IOVCC=1.65~3.30V



| Item | Symbol | Unit | Min. | Typ. | Max. |
|---|----------------|-------|------|------|------|
| VSYNC/HSYNC setup time | TSYNCS | clock | 0 | - | 1 |
| ENABLE setup time | TENS | ns | 10 | - | - |
| ENABLE hold time | TENH | ns | 25 | - | - |
| DOTCLK low-level pulse width | PWDL | ns | 25 | - | - |
| DOTCLK high-level pulse width | PWDH | ns | 25 | - | - |
| DOTCLK cycle time | TCYCD | ns | 60 | - | - |
| Data setup time | TPDS | ns | 10 | - | - |
| Data hold time | TPDH | ns | 25 | - | - |
| DOTCLK, VSYNC, and HSYNC rise/fall time | Trgb Ttrgbf | ns | - | - | 25 |



8. ELECTRO-OPTICAL CHARACTERISTICS

| Item | Symbol | Condition | Min | Typ | Max | Unit | Remark |
|--------------------|--------------------------------|-----------------------------|---------------------|-------|-------|-------------------|--------|
| Brightness | L | White pattern | 160 | 200 | - | cd/m ² | |
| Response time | T _R +T _F | $\Theta = \phi = 0$ | - | 25 | - | ms | Note 2 |
| Contrast ratio | CR | At the center point of A.A. | 300 | 350 | - | | |
| Color Chromaticity | White | W _x | $\Theta = \phi = 0$ | 0.273 | 0.313 | 0.353 | Note 2 |
| | | W _y | | 0.289 | 0.329 | 0.369 | |
| Viewing Angle | Horizontal | CR 10 | - | 110 | - | Degree | |
| | Vertical | | - | 120 | - | | |

Note.1 These items are measured by C light.

Note.2 Definition of Viewing Angle(θ , ϕ),refer to Fig.1 as below :

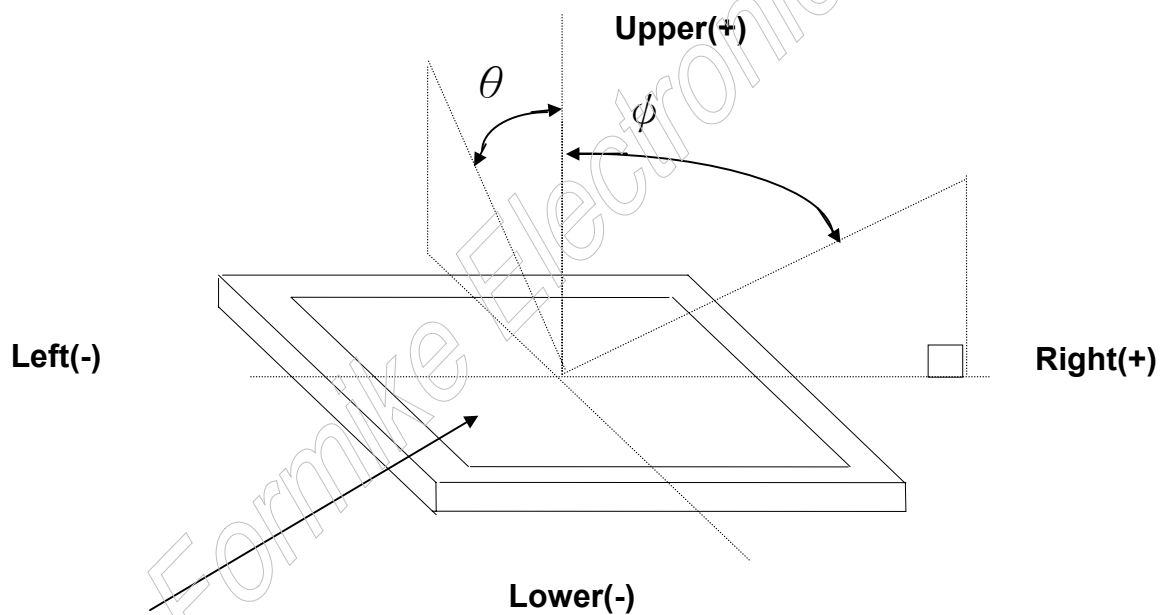

I. CF substrate

Fig.1 Definition of Viewing Angle



9. RELIABILITY

9.1.MTTF

The LCD module shall be designed to meet a minimum MTTF value of 50,000 hours with normal condition. (25°C in the room without sunlight; not include life time of backlight).

9.2.Tests

| NO. | ITEM | CONDITION | CRITERION |
|-----|---|--|--|
| 1 | High Temperature Operating | 70°C 240 hrs | <ul style="list-style-type: none"> ◦ No defect of Operational function in room temperature are allowable. ◦ Leakage current should be below double of initial value. |
| 2 | Low Temperature Operating | -20°C 240 hrs | |
| 3 | High Temperature Non-Operating | 80°C 240 hrs | |
| 4 | Low Temperature Non-Operating | -30°C 240 hrs | |
| 5 | High Temperature/ Humidity Non-Operating | 50°C,90%RH 240 hrs | |
| 6 | Temperature Shock Non-Operating | -30°C ← → 80°C (30min) (5min) (30min) 10 CYCLES | |
| 7 | Electro-static Discharge | HBM: ±2KV | |

Note 1: Test after 24 hours in room temperature.

Note 2: The sampling above is individually for each reliability testing condition.

Note 3: The color fading of polarizing filter should not care.

Note 4: All of the reliability testing chamber above, is using D.I. water.(Min value:1.0 MΩ-cm)

Note 5: In case of malfunction defect caused by ESD damage, if it would be recovered to normal state after resetting, it would be judged as a good part.

9.3.Color performance

| No. | ITEM | Criterion (initial) |
|-----|----------------|---------------------|
| 1 | Luminance | >50% |
| 2 | NTSC | >70% |
| 3 | Contrast Ratio | >50% |



10. RoHS COMPLIANT WARRANTY

RoHS Hazardous substances including:

- Cd < 100 ppm
- Pb < 1000 ppm
- Hg < 1000 ppm
- Cr +6 < 1000 ppm
- PBDE < 1000 ppm
- PBB < 1000 ppm

11. PRECAUTIONS FOR USE

11.1. Safety

- (1) Do not swallow any liquid crystal, even if there is no proof that liquid crystal is poisonous.
- (2) If the LCD panel breaks, be careful not to get liquid crystal to touch your skin.
- (3) If skin is exposed to liquid crystal, wash the area thoroughly with alcohol or soap.

11.2. Storage Conditions

- (1) Store the panel or module in a dark place where the temperature is $23\pm 5^{\circ}\text{C}$ and the humidity is below $50\pm 20\%\text{RH}$.
- (2) Store in anti-static electricity container.
- (3) Store in clean environment, free from dust, active gas, and solvent.
- (4) Do not place the module near organics solvents or corrosive gases.
- (5) Do not crush, shake, or jolt the module.
- (6) Do not exposed to direct sun light of fluorescent lamps.

11.3. Installing LCD Module

Attend to the following items when installing the LCM.

- (1) Cover the surface with a transparent protective plate or touch panel to protect the polarizer and LC cell.
- (2) When assembling the LCM into other equipment, the spacer to the bit between the LCM and the fitting plate should have enough height to avoid causing stress to the module surface, refer to the individual specifications for measurements. The



measurement tolerance should be $\pm 0.1\text{mm}$.

11.4.Precautions For Operation

- (1) Viewing angle varies with the change of liquid crystal driving voltage (V_0). Adjust V_0 to show the best contrast.
- (2) Driving the LCD in the voltage above the limit will shorten its lifetime.
- (3) Response time is greatly delayed at temperature below the operating temperature range. However, this does not mean the LCD will be out of the order. It will recover when it returns to the specified temperature range.
- (4) When turning the power on, input each signal after the positive/negative voltage becomes stable.
- (5) Do not apply water or any liquid on product which composed of T/P.

11.5.Handling Precautions

- (1) Avoid static electricity which can damage the CMOS LSI; please wear the wrist strap when handling.
- (2) The polarizing plate of the display is very fragile. so, please handle it very carefully.
- (3) Do not give external shock.
- (4) Do not apply excessive force on the surface; it may cause display abnormal .
- (5) Do not wipe the polarizing plate with a dry cloth, as it may easily scratch the surface of plate.
- (6) Do not use ketonics solvent & Aromatic solvent, use with a soft cloth soaked with a cleaning naphtha solvent.
- (7) Do not operate it above the absolute maximum rating.
- (8) Do not remove the panel or frame from the module.
- (9) Do not apply water or any liquid on product, which composed of T/P.

11.6.Warranty

- (1) The period is within 12 months since the date of shipping out under normal using and storage conditions.
- (2) The warranty will be avoided in case of defect induced by customer.