



FORMIKE ELECTRONIC CO.,LTD

PRODUCT SPECIFICATION

TFT LCD MODULE

MODEL : KWH018TG01-F01

Ver. B

【 ◆ 】 Preliminary Specification

【 】 Finally Specification

CUSTOMER'S APPROVAL	
SIGNATURE:	DATE:

APPROVED BY	PM REVIEWD	PD REVIEWD	PREPARED BY
Kam	/	Stephen	Roy

Prepared By :

FORMIKE ELECTRONIC CO.,LTD

Address :Room A818 New Energy Building, NanHai Road, NanShan District, ShenZhen, China. 518054

TEL:(86) 755 88306921,88306931 FAX:(86) 755 88304615

Http:// www.wandisplay.com

- This specification is subject to change without notice.Please contact FORMIKE or it's representative before designing your product based on this specification.

Issued Date: Aug - 21-2009



CONTENTS

	Page
1.NOTICE	1
2.General Specifications.....	5
3. Outline Drawing	6
4. Circuit Block Diagram	7
5. Absolute Maximum Ratings(Ta=25°C).....	8
6. Electrical Specifications and Instruction Code.....	9
7. Optical Characteristics (VDD=2.8V,Vss=0V ,Ta=25°C)	23
8.Initial Code Setting	27
9. Reliability Test Items and Criteria	29
10 Quality level.....	31
11. Package Method	36



1.NOTICE

1.1 announce

1.1.1 These specification sheets are the proprietary product of FORMIKE and include materials protected under copyright of FORMIKE . Do not reproduce or cause any third party to reproduce them in any form or by any means, electronic or mechanical, for any purpose,in whole or in part,without the express written permission of FORMIKE . FORMIKE assumes no responsibility for any problems related to any industrial property right of a third party resulting from the use of the device.

1.1.2 Do not use the device for equipment that requires an extreme level of reliability, such as aerospace applications, nuclear power control equipment and medical or other equipment for life support. FORMIKE assumes no responsibility for any damage resulting from the use of the device which does not comply with the instructions and the precautions specified in these specification sheets.

1.1.3 Contact and consult. with a FORMIKE sales representative for any questions about this device.

1.2 For handling and system design

1.2.1 Do not scratch the surface of the polarizer film as it is easily damaged.

1.2.2 If the cleaning of the surface of the LCD panel is necessary, wipe it swiftly with cotton or other soft cloth. Do not use organic solvent as it damages polarizer.

1.2.3 Water droplets on polarizer must be wiped off immediately as they may cause color changes, or other defects if remained for a long time.

1.2.4 Since this LCD panel is made of glass, dropping the module or banging it against hard objects may cause cracks or fragmentation.

1.2.5 Certain materials such as epoxy resin (amine's hardener) or silicone adhesive agent (de-alcohol or de-oxy) emits gas to which polarizer reacts (color change). Check carefully that gas from materials used in system housing or packing do not harm polarizer.

1.2.6 Liquid crystal material will freeze below specified storage temperature range and it will not get back to normal quality even after temperature comes back within specified temperature range. Liquid crystal material will become isotropic above specified temperature range and may not get back to normal quality. Keep the LCD module always within specified temperature range.

1.2.7 Do not expose LCD module to the direct sunlight, or to strong ultraviolet light for long time. If the LCD driver IC is exposed to light, normal operation may be impeded. It is necessary to design so that the light is shut off when the LCD module is mounted.

1.2 Do not disassemble the LCD module as it may cause permanent damage. Hold LCD very carefully when placing LCD module into the system housing. Do not apply excessive stress or pressure to LCD module.

1.2.9 As this LCD module contains components sensitive to electrostatic discharge, be sure to follow the instructions in below.

① Operators

Operators must wear anti-static wears to prevent electrostatic charge up to and discharge

from human body.

②Equipment and containers

Process equipment such as conveyer, soldering iron, working bench and containers may possibly generate electrostatic charge up and discharge. Equipment must be grounded through 100Mohms resistance. Use ion blower.

③Floor

Floor is an important part to leak static electricity which is generated from human body or equipment. There is a possibility that the static electricity is charged to them without leakage .in case of insulating floor, so the countermeasure(electrostatic earth: $1 \times 10^8 \Omega$) should be made.

④Humidity

Proper umidityof working roommay reduce the isk ofelectrostatic charge up and discharge. Humidity should be kept over 50% all the time.

⑤Transportation/storage

Storage materials must be anti-static to prevent causing electrostatic discharge.

⑥Others

Protective film is attached on the surface of LCD panel to prevent scratches or other damage. When removing this protective film, remove it slowly under proper anti-ESD control such as ion blower.

1.2.10 Do not hold or touch LCD panel to flex interconnection area as it may be damaged. As the binding material between LCD panel and flex connector mentioned in flex area contains an organic material, any type of organic solvents are not allowed to be used. Direct contact by fingers are also prohibited.

1.2.11 When carrying the LCD module, place it on the tray to protect from mechanical damage.

It is recommended to use the conductive trays to protect the CMOS components from electrostatic discharge. When holding the module, hold the Plastic Frame of LCD module so that the panel ,TCP and other electric parts are not damaged. e.g. chart1

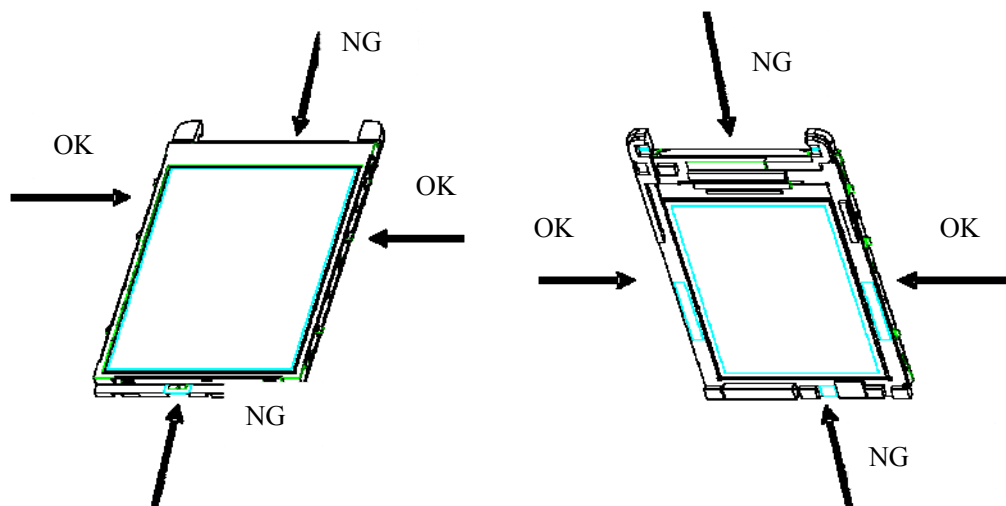

chart1 Note : The LCD module illustration is general module image



1.2.12 Do not touch the FPC 's exposed base film and patterning area, slit part. Otherwise the circuit maybe damaged. Do not touch LSI chips as it may cause a trouble in the inner lead connection.

1.2.13 Place a protective cover on the LCD module to protect the glass panel from mechanical damages.

1.2.14 LCD panel is susceptible to mechanical stress and even the slightest stress will cause a color change

in background.So make sure the LCD panel is placed on flat plane without any continuous twisting, bending or pushing stress.

1.2.15 Protective film is placed onto the surface of LCD panel when it is shipped from factory. Make sure to peel it off before assembling the LCD module into the system. Be very careful not to damage LCD module by electrostatic discharge when peeling off this protective film. Ion blower and ground strap are recommended.

1.2.16 Make sure the mechanical design of the system in which the LCD module will be assembled matches specified viewing angle of this LCD module.

1.3 For operating LCD module

1.3.1 Do not operate or store the LCD module under outside of specified environmental conditions.

1.3.2 As opto-electrical characteristics of LCD will be changed, dependent on the temperature, the confirmation of display quality and characteristics has to be done after temperature is set at 25 °C and it becomes stable.

1.4 Precautions for Storage

1.4.1 Do not expose the LCD module to direct sunlight or strong ultraviolet light for long periods. Store in a dark place.

1.4.2 The liquid crystal material will solidify if stored below the rated storage temperature and will become an isotropic liquid if stored above the rated storage temperature, and may not retain its original properties. Only store the module at normal temperature and humidity (25±5°C、60±10% RH) in order to avoid exposing the front polarizer to chronic humidity.

1.4.3 Keeping method

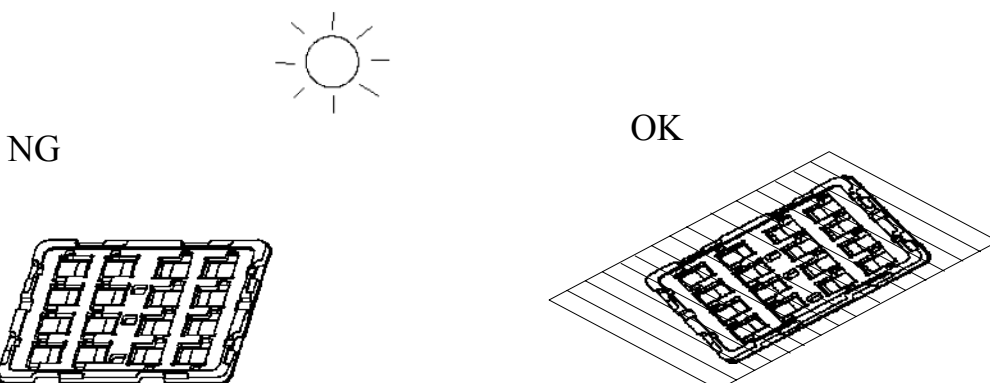

a. Don't keeping under the direct sunlight.

b. Keeping in the tray under the dark place

1.5 Other Notice

1.5.1 Generally, At power on, in order not to apply DC charge directly to LCD panel, supply



logic voltage first and initialize LSI logic function including polarity alternation. Then supply voltage for LCD bias. At power off, in order not to apply DC charge directly to LCD panel, execute Power OFF sequence and Discharge command.

1.5.2 Don't touch to PWB surface, exposed IC chip, electric parts and other parts, to any electric, metallic materials.

1.5.3 No bromide specific fire-retardant material is used in this module.

1.5.4 If the display panel is damaged and the liquid crystal substance inside it leaks out, be sure not to get any in your mouth, if the substance comes into contact with your skin or clothes, promptly wash it off using soap and water.



2.General Specifications

KWH018TG01-F01 is a color active matrix LCD module incorporating amorphous silicon TFT (Thin Film Transistor). It is composed of a color TFT-LCD panel, driver IC, FPC and a back light unit. The 1.77" display area contains 128 x 160 pixels and can display up to 262K colors. This product accords with RoHS environmental criterion.

Item	Contents	Unit	Note
LCD Type	TFT	-	
Display Color	65K/262K		1
LCD Duty	1/160	-	
Viewing Direction	6:00	O'Clock	
Active Area(W×H)	28.03×35.04	mm	
Number of Dots	128(RGB)×160	mm	
Dot Pitch(W×H)	0.219X0.219	mm	
Controller	ILI9163B	-	
V _{DD}	2.8	V	
Outline Dimensions	Refer to outline drawing on next page		
Backlight	2-LED(white)	-	
Weight	TBD	g	
Interface	8bits parallel bus	-	
Polarizer Mode	Transmissive/Positive	-	

Note 1: Color tune is slightly changed by temperature and driving voltage.

Note 2: Requirements on Environmental Protection: RoHS

Note 3: Customer should do assembly according to our FPC bending sketch in the outline drawing.

Note 4: Please approve our spec before placing mass production order. Otherwise we will regard customer has approved the spec when we receive the first 2Kpcs or above order from customer.



4. Circuit Block Diagram

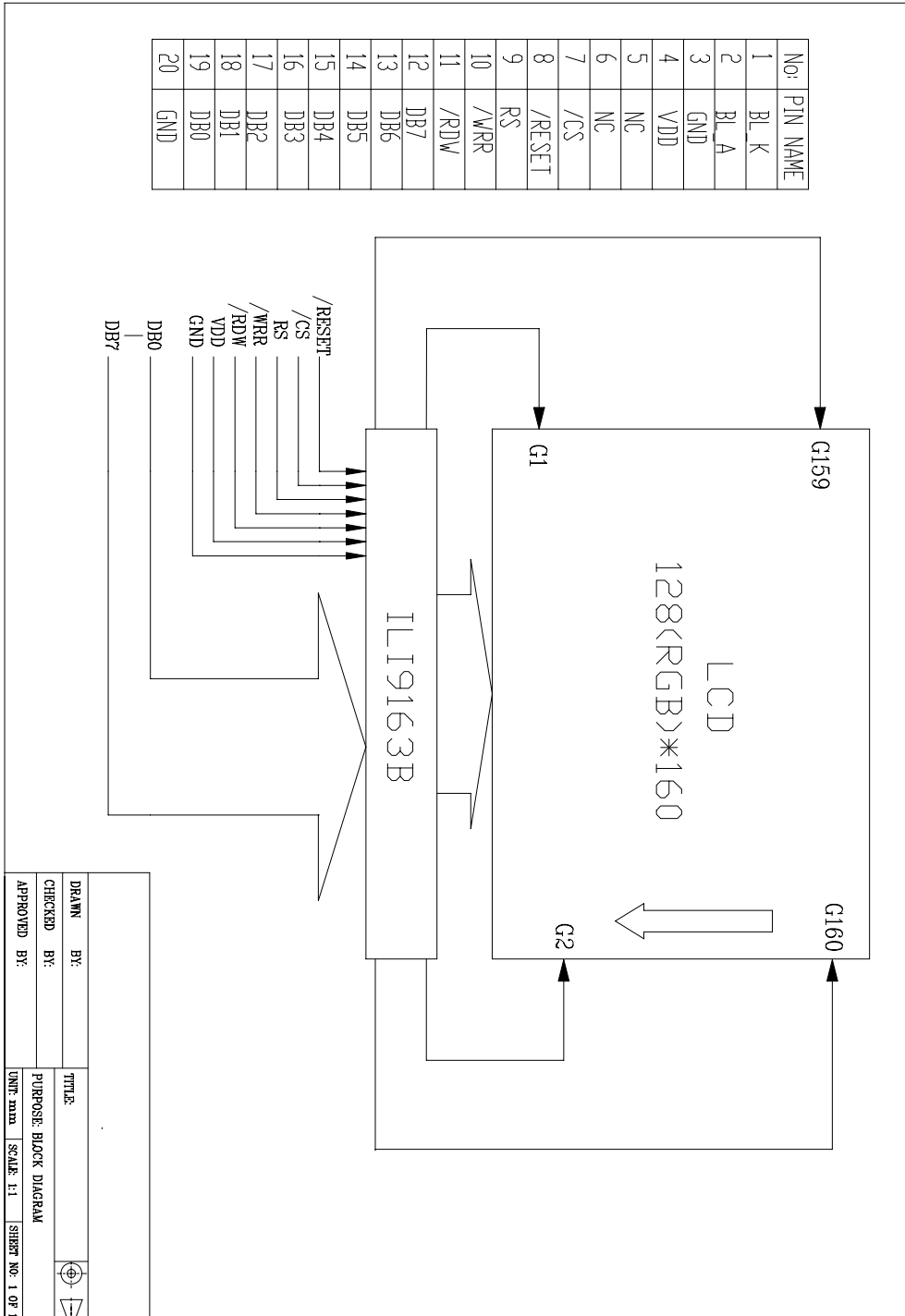



5. Absolute Maximum Ratings(Ta=25°C)

Item	Symbol	Min.	Max.	Unit	Note
Power Supply Voltage	V _{DD}	-0.3	4.6	V	1 , 2,3
Operating Temperature	Top	-20	+70	°C	
Storage Temperature	Tst	-30	+80	°C	

Notes:

1. In case of below 0°C , the response time of liquid crystal (LC) becomes slower and the color of panel becomes darker than normal one. Level of retardation depends on temperature, because of LC's characteristics.
2. If the module is above these absolute maximum ratings. It may become permanently damaged. Using the module within the following electrical characteristic conditions are also exceeded, the module will malfunction and cause poor reliability.
3. V_{DD} > V_{SS} must be maintained.



6. Electrical Specifications and Instruction Code

6.1 Electrical characteristics(V_{SS}=0V ,T_a=25°C)

Parameter	Symbol	Condition	Min	Typ	Max	Unit	Note
Input voltage	'H'	V _{IH}	0.7 V _{DD}	-	V _{DD}	V	
	'L'	V _{IL}	V _{SS}	-	0.3 V _{DD}	V	
Output Voltage	'H'	V _{OH}	I _{OH} = -1.0mA	0.8 V _{DD}	-	V _{DD}	V
	'L'	V _{OL}	I _{OL} = +1.0mA	V _{SS}	-	0.2 V _{DD}	V
Current Consumption	I _{CC1}	Normal mode	-	-	-	mA	1,3
	I _{CC2}	Standby mode	-	-	-	mA	2

Note:

1: Display full white. Backlight on state.

2: IC on standby mode.

3: the default voltage is 3.2V, for N lights in series, the power is that the current multiply N.

6.2 LED backlight specification(VDD=2.8V,Vss=0V ,Ta=25°C)

Item	Symbol	Condition	Min	Typ	Max	Unit	Note
Supply voltage	V _f	I _f =30mA	-	3.2	-	V	1
Reverse voltage	V _r	-	-	-	-	V	
Forward current	Normal	2-chip		30		mA	2
	Dimming			I _{pd}			
Reverse Current	I _r	-	-	-	-	μA	
Uniformity	ΔBp	I _f =30mA	80%				
Color coordinate*	X		0.270	-	0.315	-	
	Y		0.270	-	0.315	-	

White LED CIRCUIT DIAGRAM:

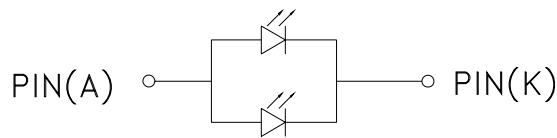

CIRCUIT DIAGRAM
 I_F=30mA (CONSTANT
 CURRENT) U=3. 1-3. 5V

NOTE:

- 1 The LED 's driver mode needs to be constant **current** mode.
- 2 Permanent damage to the device may occur if maximum values are exceeded or reverse voltage is loaded .Functional operation should be restricted to the conditions described under normal operating conditions.



6.3 Interface Signals

Pin No.	Symbol	I/O	Function
1	BL_K	I	Cathode for LED backlighting
2	BL_A	I	Anode for LED backlighting
3	GND	P	Power ground
4	VDD	P	Power Supply for Analog Circuit
5	NC		
6	NC		
7	/CS	I	Chip select signal
8	/RESET	I	Chip reset pin
9	RS	I	Data/command selection pin
10	/WRR	I	Write execution control pin
11	/RDW	I	Read execution control pin
12	DB7	I/O	Display data input
13	DB6	I/O	Display data input
14	DB5	I/O	Display data input
15	DB4	I/O	Display data input
16	DB3	I/O	Display data input
17	DB2	I/O	Display data input
18	DB1	I/O	Display data input
19	DB0	I/O	Display data input
20	GND	P	Power ground



6.4 Interface Timing Chart

Note: Please refer to ILITEK's [ILI9163B](#) data sheet for more details.

ILITEK's [ILI9163B](#) INTERFACE PROTOCOL Inter 80 system CPU interface

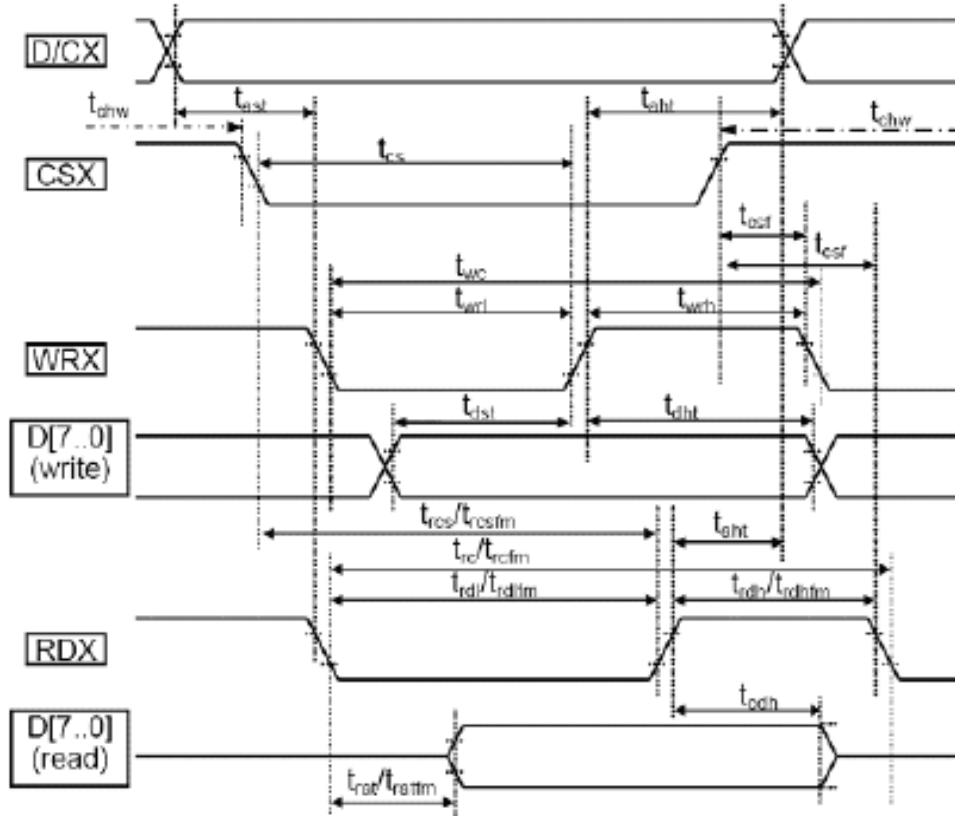

Signal	Symbol	Parameter	min	max	unit	description
D/CX	t _{ast}	Address setup time	0		ns	
	t _{ah}	Address hold time(Write/Read)	10		ns	
CSX	t _{chw}	*S**H* Pulse Width	0		ns	
	t _{cs}	Chip Select setup time (Write)	10		ns	
	t _{rcs}	Chip Select setup time (Read ID)	45		ns	
	t _{trcsfm}	Chip Select setup time (Read FM)	355		ns	
	t _{csf}	Chip Select Wait time(Write/read)	10		ns	
WRX	t _{wc}	Write cycle	66		ns	
	t _{wrh}	Controlpulse H duration	15		ns	
	t _{wrl}	Control pulse L duration	15		ns	
RDX	t _{rc}	Read cycle (ID)	160		ns	When read ID data
	t _{rdh}	Control pulse H duration(ID)	90		ns	
	t _{rdl}	Control pulse L duration(ID)	45		ns	



RDX	trcfm	Read cycle (FM)	450		ns	When read from frame memory
	trdhfm	Control pulse H duration (FM)	90		ns	
	trdlfm	Control pulse L duration (FM)	355		ns	
D[17..0]	tdst	Data setup time	10		ns	For maximum CL= 30pF
	tdht	Data hold time	10		ns	
	trat	Read access time (ID)		40	ns	For minimum CL= 8pF
	trafm	Read access time (FM)		340	ns	
	todh	Output disable time	20	80	ns	

Note 1: VDDI 1.65 to 3.3V, VDD=2.6 to 3.3V, AGND=GND=0V, Ta=-30 to 70 °C (to +85°C no damage)

Note 2: This input signal rise time and fall time (tr, tf) is specified at 15 ns or less. Logic high and low levels are specified as 30% and 70% of VDDI for input signals



INSTRUCTION DESCRIPTION(ILITEK's [IL9163B](#))

Hex code	Command	D17-D8	D7	D6	D5	D4	D3	D2	D1	D0	HEX
00H	NOP (No Operation)	X	0	0	0	0	0	0	0	0	00h
01H	Software Reset	X	0	0	0	0	0	0	0	1	01h
04H	Read Display Identification Information	x	0	0	0	0	0	1	0	0	04h
	1 st Parameter	x	x	x	x	x	x	x	x	x	x
	2 nd Parameter	x	ID17	ID16	ID15	ID14	ID13	ID12	ID11	ID10	54h
	3 rd Parameter	x	ID27	ID26	ID25	ID24	ID23	ID22	ID21	ID20	80h
	4 th Parameter	x	ID37	ID36	ID35	ID34	ID33	ID32	ID31	ID30	66h
09H	Read Display Status	x	0	0	0	0	1	0	0	1	09h
	1 st Parameter	x	x	x	x	x	x	x	x	x	x
	2 nd Parameter	x	DOTSON	MY	MX	MV	ML	RGB	MH	ST24	x
	3 rd Parameter	x	ST23	IFPF2	IFPF1	IFPF0	IDMON	PTLON	SLCUT	NORON	x
	4 th Parameter	x	VSSON	ST14	INVON	ST12	ST11	DISON	TEON	GCS2	x
	5 th Parameter	x	GCS1	GCS0	TELOM	HSON	VSON	PCKON	DEON	ST0	x
0AH	Read Display Power Mode	x	0	0	0	0	1	0	1	0	0Ah
	1 st Parameter	x	x	x	x	x	x	x	x	x	x
	2 nd Parameter	x	D7	D6	D5	D4	D3	D2	D1	D0	08h
0BH	Read Display MADCTL	x	0	0	0	0	1	0	1	1	0Bh
	1 st Parameter	x	x	x	x	x	x	x	x	x	x
	2 nd Parameter	x	D7	D6	D5	D4	D3	D2	D1	D0	00h
0CH	Read Display Pixel Format	x	0	0	0	0	1	1	0	0	0Ch
	1 st Parameter	x	x	x	x	x	x	x	x	x	x
	2 nd Parameter	x	x	x	x	x	D3	IFPF2	IFPF1	IFPF0	66h
0DH	Read Display Image Mode	x	0	0	0	0	1	1	0	1	0Dh
	1 st Parameter	x	x	x	x	x	x	x	x	x	x
	2 nd Parameter	x	D7	D6	D5	D4	D3	D2	D1	D0	00h



0EH	Read Display Signal Mode	x	0	0	0	0	1	1	1	0	0Eh
	1 st Parameter	x	x	x	x	x	x	x	x	x	x
	2 nd Parameter	x	D7	D6	x	x	x	x	0	0	00h
0FH	Read Display Signal Mode	x	0	0	0	0	1	1	1	1	0Fh
	1 st Parameter	x	x	x	x	x	x	x	x	x	x
	2 nd Parameter	x	D7	D6	D5	D4	D3	D2	D1	D0	00h
10H	Sleep In	x	0	0	0	1	0	0	0	0	10h
11H	Sleep Out	x	0	0	0	1	0	0	0	1	11h
12H	Partial Mode On	x	0	0	0	1	0	0	1	0	12h
13H	Normal Display Mode On	x	0	0	0	1	0	0	1	1	13h
20H	Display Inversion Off	x	0	0	1	0	0	0	0	0	20h
21H	Display Inversion On	x	0	0	1	0	0	0	0	1	21h
26H	Gamma Set	x	0	0	1	0	0	1	1	0	26h
	1 st Parameter	x	GC7	GC6	GC5	GC4	GC3	GC2	GC1	GC0	01h
28H	Display Off	x	0	0	1	0	1	0	0	0	28h
29H	Display On	x	0	0	1	0	1	0	0	1	29h
2AH	Column Address Set	x	0	0	1	0	1	0	1	0	2Ah
	1 st Parameter	x	XS15	XS14	XS13	XS12	XS11	XS10	XS9	XS8	-



	2 nd Parameter	x	XS7	XS6	XS5	XS4	XS3	XS2	XS1	XS0	-
	3 rd Parameter	x	XE15	XE14	XE13	XE12	XE11	XE10	XE9	XE8	-
	4 th Parameter	x	XE7	XE6	XE5	XE4	XE3	XE2	XE1	XE0	-
2BH	Page Address Set	x	0	0	1	0	1	0	1	1	2Bh
	1 st Parameter	x	YS15	YS14	YS13	YS12	YS11	YS10	YS9	YS8	-
	2 nd Parameter	x	YS7	YS6	YS5	YS4	YS3	YS2	YS1	YS0	-
	3 rd Parameter	x	YE15	YE14	YE13	YE12	YE11	YE10	YE9	YE8	-
	4 th Parameter	x	YE7	YE6	YE5	YE4	YE3	YE2	YE1	YE0	-
2CH	Memory Write	x	0	0	1	0	1	1	0	0	2Ch
	1 st Parameter	D17-8	D7	D6	D5	D4	D3	D2	D1	D0	-
	:	x	:	:	:	:	:	:	:	:	:
	N th Parameter	D17-8	D7	D6	D5	D4	D3	D2	D1	D0	-
2DH	Color Setting for 4K, 65K and 262K	x	0	0	1	0	1	1	0	1	2Dh
	1 st Parameter	x	x	x	R005	R004	R003	R002	R001	R000	-
	:	x	x	x	Rnn5	Rnn4	Rnn3	Rnn2	Rnn1	Rnn0	-
	32 nd parameter	x	x	x	R315	R314	R313	R312	R311	R310	-
	33 rd Parameter	x	x	x	G005	G004	G003	G002	G001	G000	-
	:	x	x	x	Gnn5	Gnn4	Gnn3	Gnn2	Gnn1	Gnn0	-
	96 th Parameter	x	x	x	G635	G634	G633	G632	G631	G630	-
	97 th Parameter	x	x	x	B005	B004	B003	B002	B001	B000	-
	:	x	x	x	Bnn5	Bnn4	Bnn3	Bnn2	Bnn1	Bnn0	-
	128 th Parameter	x	x	x	B315	B314	B313	B312	B311	B310	-
2EH	Memory Read	x	0	0	1	0	1	1	1	0	2Eh
	1 st Parameter	x	x	x	x	x	x	x	x	x	-
	2 nd Parameter	x	D17	D16	D15	D14	D13	D12	D11	D10	-
	:	x	:	:	:	:	:	:	:	:	-
	N th Parameter	x	Dn7	Dn6	Dn5	Dn4	Dn3	Dn2	Dn1	Dn0	-
30H	Partial Area	x	0	0	1	1	0	0	0	0	30h



	1 st Parameter	x	PSL 15	PSL 14	PSL 13	PSL 12	PSL 11	PSL 10	PSL 9	PSL 8	-
	2 nd Parameter	x	PSL 7	PSL 6	PSL 5	PSL 4	PSL 3	PSL 2	PSL 1	PSL 0	-
	3 rd Parameter	x	PEL 15	PEL 14	PEL 13	PEL 12	PEL 1	PEL 10	PEL 9	PEL 8	-
	4 th Parameter	x	PEL 7	PEL 6	PEL 5	PEL 4	PEL 3	PEL 2	PEL 1	PEL 0	-
33H	Vertical Scrolling Definition	x	0	0	1	1	0	0	1	1	33h
	1 st Parameter	x	TFA 15	TFA 14	TFA 13	TFA 12	TFA 11	TFA 10	TFA 9	TFA 8	-
	2 nd Parameter	x	TFA 7	TFA 6	TFA 5	TFA 4	TFA 3	TFA 2	TFA 1	TFA 0	-
	3 rd Parameter	x	VSA 15	VSA 14	VSA 13	VSA 12	VSA 11	VSA 10	VSA 9	VSA 8	-
	4 th Parameter	x	VSA 7	VSA 6	VSA 5	VSA 4	VSA 3	VSA 2	VSA 1	VSA 0	-
	5 th Parameter	x	BFA 15	BFA 14	BFA 13	BFA 12	BFA 11	BFA 10	BFA 9	BFA 8	-
	6 th Parameter	x	BFA 7	BFA 6	BFA 5	BFA 4	BFA 3	BFA 2	BFA 1	BFA 0	-
34H	Tearing Effect Line Off	x	0	0	1	1	0	1	0	0	34h
35H	Tearing Effect Line On	x	0	0	1	1	0	1	0	1	35h
	1 st Parameter	x	x	x	x	x	x	x	x	M	00h
36H	Memory Access Control	x	0	0	1	1	0	1	1	0	36h
	1 st Parameter	x	MY	MX	MV	ML	RGB	MH	x	x	00h
37H	Vertical Scrolling Start Address	x	0	0	1	1	0	1	1	1	37h
	1 st Parameter	x	SSA 15	SSA 14	SSA 13	SSA 12	SSA 11	SSA 10	SSA 9	SSA 8	00h
	2 nd Parameter	x	SSA 7	SSA 6	SSA 5	SSA 4	SSA 3	SSA 2	SSA 1	SSA 0	00h
38H	Idle Mode Off	x	0	0	1	1	1	0	0	0	38h
39H	Idle Mode On	x	0	0	1	1	1	0	0	1	39h



3AH	Interface Pixel Format	x	0	0	1	1	1	0	1	0	3Ah
	1 st Parameter	x	VIPF3	VIPF2	VIPF1	VIPF0	D3	IFPF2	IFPF1	IFPF0	66h
B1H	Frame Rate Control(In normal mode/Full colors)		1	0	1	1	0	0	0	1	B1h
	1 st Parameter		x	x	x	DVA4	DVA3	DVA2	DVA1	DVA0	x
	2 nd Parameter		x	x	VPA5	VPA4	VPA3	VPA2	VPA1	VPA0	x
B2H	Frame Rate Control(In Idle mode/8-colors)		1	0	1	1	0	0	1	0	B2h
	1 st Parameter		x	x	x	DVB4	DVB3	DVB2	DVB1	DVB0	x
	2 nd Parameter		x	x	VPB5	VPB4	VPB3	VPB2	VPB1	VPB0	x
B3H	Frame Rate Control(In Partial mode/full colors)		1	0	1	1	0	0	1	1	B3h
	1 st Parameter		x	x	x	DVC4	DVC3	DVC2	DVC1	DVC0	x
	2 nd Parameter		x	x	VPC5	VPC4	VPC3	VPC2	VPC1	VPC0	x
B4H	Display Inversion Control	x	1	0	1	1	0	1	0	0	B4h
	1 st Parameter	x	0	0	0	0	0	NLA	NLB	NLC	02H
B5H	RGB Interface Blanking Porch setting	x	1	0	1	1	0	1	0	1	B5h
	1 st Parameter	x	x	x	HBP5	HBP4	HBP3	HBP2	HBP1	HBP0	08h
	2 nd Parameter	x	VBP7	VBP6	VBP5	VBP4	VBP3	VBP2	VBP1	VBP0	03h
	3 rd Parameter	x	x	x	x	x	x	x	VBP9	VBP8	00h
B7H	Source Driver Direction Control	x	1	0	1	1	0	1	1	1	B7h



	1 st Parameter	x	0	0	0	0	0	0	0	CRL	00h
B8H	Gate Driver Direction Control	x	1	0	1	1	1	0	0	0	B8h
	1 st Parameter	x	0	0	0	0	0	0	0	CTB	00h
C0H	Power_ Control1	x	1	1	0	0	0	0	0	0	C0h
	1 st Parameter	x	0	0	0	VRH4	VRH3	VRH2	VRH1	VRH0	x
	2 nd Parameter	x	0	0	0	0	0	VC2	VC1	VC0	02h
C1H	Power_ Control2	x	1	1	0	0	0	0	0	1	C1h
	1 st Parameter	x	0	0	0	0	0	BT2	BT1	BT0	07h
C2H	Power_ Control3	x	1	1	0	0	0	0	1	0	C2h
	1 st Parameter	x	0	0	0	0	0	APA2	APA1	APA0	00h
	2 nd Parameter	x	0	0	0	0	0	DCA2	DCA1	DCA0	06h
C3H	Power_ Control4	x	1	1	0	0	0	0	1	1	C3h
	1 st Parameter	x	0	0	0	0	0	APB2	APB1	APB0	00h
	2 nd Parameter	x	0	0	0	0	0	DCB2	DCB1	DCB0	07h
C4H	Power_ Control 5	x	1	1	0	0	0	1	0	0	C4h
	1 st Parameter	x	0	0	0	0	0	APC2	APC1	APC1	01h
	2 nd Parameter	x	0	0	0	0	0	DCC2	DCC1	DCC0	07h
C5H	VCOM_ Control 1	x	1	1	0	0	0	1	0	1	C5h
	1 st Parameter	x	x	VMH 6	VMH 5	VMH 4	VMH 3	VMH 2	VMH 1	VMH 0	-
	2 nd Parameter	x	0	VML 6	VML 5	VML 4	VML 3	VML 2	VML 1	VML 0	-
C6H	VCOM_ Control 2	x	1	1	0	0	0	1	1	0	C6h
	1 st Parameter	x	0	0	VMA	VMA	VMA	VMA	VMA	VMA	13h/



					5	4	3	2	1	0	06h
C7H	VCOM Offset										
	Control	x	1	1	0	0	0	1	1	1	C7h
	1 st Parameter	0	nVM*	VMF6	VMF5	VMF4	VMF3	VMF2	VMF1	VMF0	40h
D3H	Write ID4										
	Value	x	1	1	0	1	0	0	1	1	D3h
	1 st Parameter	x	x	x	x	x	x	x	x	x	x
	2 nd Parameter	x	ID417	ID416	ID415	ID414	ID413	ID412	ID411	ID410	01h
	3 rd Parameter	x	ID427	ID426	ID425	ID424	ID423	ID422	ID421	ID420	21h
	4 th Parameter	x	x	x	x	x	ID433	ID432	ID431	ID430	x
D5H	NV Memory										
	Function										
	Controller(1)	x	1	1	0	1	1	0	1	0	D5h
D6H	1 st Parameter	x	ID33	ID32	ID31	ID30	ID23	ID22	ID21	ID20	00h
	2 nd Parameter	x	OTP_ BS	0	0	0	OTP_ VMF3	OTP_ VMF2	OTP_ VMF1	OTP_ VMF0	00h
D7H	NV Memory										
	Function										
	Controller(2)	x	1	1	0	1	1	0	1	0	D6h
D7H	1 st Parameter	x	OTP_ D[7]	OTP_ D[6]	OTP_ D[5]	OTP_ D[4]	OTP_ D[3]	OTP_ D[2]	OTP_ D[1]	OTP_ D[0]	00h
	2 nd Parameter	x	0	0	0	0	0	0	OTP_ TP[1]	OTP_ TP[0]	00h
DAH	NV Memory										
	Function										
	Controller(3)	x	1	1	0	1	1	0	1	0	D7h
	1 st Parameter	x	0	1	0	1	0	1	0	1	55h
DAH	2 nd Parameter	x	1	0	1	0	1	0	1	0	AAh
	3 rd Parameter	x	0	1	1	0	0	1	1	0	66h
DAH	Read ID1	x	1	1	0	1	1	0	1	0	DAh
	1 st Parameter	x	x	x	x	x	x	x	x	x	x
	2 nd Parameter	x	ID17	ID16	ID15	ID14	ID13	ID12	ID11	ID10	54h
DBH	Read ID2	x	1	1	0	1	1	0	1	1	DBh
	1 st Parameter	x	x	x	x	x	x	x	x	x	x
	2 nd Parameter	x	1	ID26	ID25	ID24	ID23	ID22	ID21	ID20	80h
DCH	Read ID3	x	1	1	0	1	1	1	0	0	DCh
	1 st Parameter	x	x	x	x	x	x	x	x	x	x
	2 nd Parameter	x	ID37	ID36	ID35	ID34	ID33	ID32	ID31	ID30	66h
E0H	Positive		1	1	1	0	0	0	0	0	E0h



	Gamma Correction Setting											
	1 st Parameter	x	x	VP63[5:0]							-	
	2 nd Parameter	x	x	VP62[5:0]							-	
	3 rd Parameter	x	x	VP61[5:0]							-	
	4 th Parameter	x	x	VP59[5:0]							-	
	5 th Parameter	x	x	VP57[5:0]							-	
	6 th Parameter	x	x	x	VP50[4:0]						-	
	7 th Parameter	x	VP43[6:0]								-	
	8 th Parameter	VP36[3:0]			VP27[3:0]						-	
	9 th Parameter	x	VP20[6:0]								-	
	10 th Parameter	x	VP13[5:0]								-	
	11 st Parameter	x	x	VP6[5:0]							-	
	12 nd Parameter	x	x	VP4[5:0]							-	
	13 rd Parameter	x	x	VP2[5:0]							-	
	14 th Parameter	x	x	VP1[5:0]							-	
	15 th Parameter	x	x	VP0[5:0]							-	
E1H	Negative Gamma Correction Setting											
		1	1	1	0	0	0	0	1	E1h		
		1 st Parameter	x	x	VN0[5:0]							-
		2 nd Parameter	x	x	VN1[5:0]							-
		3 rd Parameter	x	x	VN2[5:0]							-
		4 th Parameter	x	x	VN4[5:0]							-
		5 th Parameter	x	x	VN6[5:0]							-
		6 th Parameter	x	x	x	VN13[4:0]						-
		7 th Parameter	x	x	VN20[6:0]							-
		8 th Parameter	VN36[3:0]			VN27[3:0]						-
		9 th Parameter	x	VN43[6:0]								-
		10 th Parameter	x	x	VN50[5:0]							-
		11 st Parameter	x	x	VN57[5:0]							-
		12 nd Parameter	x	x	VN59[5:0]							-
		13 rd Parameter	x	x	VN61[5:0]							-
	14 th Parameter	x	x	VN62[5:0]							-	
	15 th Parameter	x	x	VN63[5:0]							-	



F2H	GAM_R_SEL		1	1	1	1	0	0	1	0	F2h	14.2.
	1 st Parameter		x	x	x	x	x	x	x	GAM_ R_SEL	Write	59



7. Optical Characteristics (VDD=2.8V, Vss=0V, Ta=25°C)

Item	Symbol	Condition	Min.	Typ.	Max.	Unit	Note	
Brightness	Bp	$\theta=0^\circ$	190	-	-	Cd/m ²	1	
Uniformity	ΔBp	$\Phi=0^\circ$	80%	-	-		1,2	
Viewing Angle	θ_1 ($\Phi=90^\circ$ or 270°)	Cr \geq 10	-50~+40			Deg	3	
	θ_2 ($\Phi=0^\circ$ or 180°)							-50~+50
Contrast Ratio	Cr	$\theta=0^\circ$ $\Phi=0^\circ$	-	350	-	-	4	
Response Time	$T_{r+}+T_f$	$\theta=0^\circ$ $\Phi=0^\circ$	-	30	-	Ms	5	
						Ms		
Color of CIE Coordinate	W	$\theta=0^\circ$ $\Phi=0^\circ$	x	0.246	0.296	0.346	-	1,6
			y	0.265	0.315	0.365	-	
	R		x	0.539	0.589	0.639	-	
			y	0.297	0.347	0.397	-	
	G		x	0.284	0.334	0.384	-	
			y	0.465	0.515	0.565	-	
	B		x	0.101	0.151	0.201	-	
			y	0.059	0.109	0.159	-	
NTSC Ratio	S		42%	-				

Note : The parameter is slightly changed by temperature, driving voltage and materiel.

Note 1: The data are measured after LEDs are turned on for 5 minutes. LCM displays full white.
 The brightness is the average value of 9 measured spots. Measurement equipment PR-705 (Φ8mm)

Measuring condition:

- Measuring surroundings: Dark room.
- Measuring temperature: Ta=25°C.
- Adjust operating voltage to get optimum contrast at the center of the display.

Measured value at the center point of LCD panel after more than 5 minutes while backlight turning on.

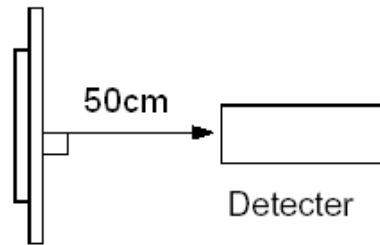

Note 2: The luminance uniformity is calculated by using following formula.

$$\Delta B_p = B_p (\text{Min.}) / B_p (\text{Max.}) \times 100 (\%)$$

$B_p (\text{Max.})$ = Maximum brightness in 9 measured spots

$B_p (\text{Min.})$ = Minimum brightness in 9 measured spots.

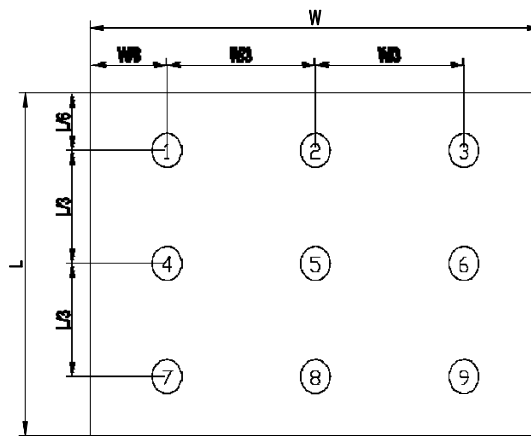

Measurement equipment PR-705 (Φ8mm)

Note 3: The definition of viewing angle:

Refer to the graph below marked by θ and ϕ

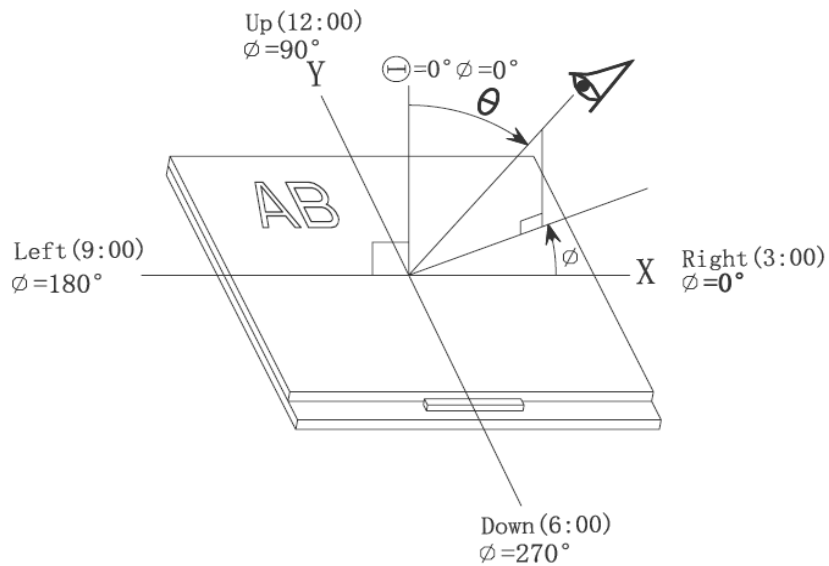

Note 4: The definition of contrast ratio (Test LCM using PR-705):

$$\text{Contrast Ratio(CR)} = \frac{\text{Luminance When LCD is at "White" state}}{\text{Luminance When LCD is at "Black" state}}$$

(Contrast Ratio is measured in optimum common electrode voltage)

Note 5: Definition of Response time. (Test LCD using DMS501):

The output signals of photo detector are measured when the input signals are changed from "black" to "white"(falling time) and from "white" to "black"(rising time), respectively. The response time is defined as the time interval between the 10% and 90% of amplitudes. Refer to figure as below.

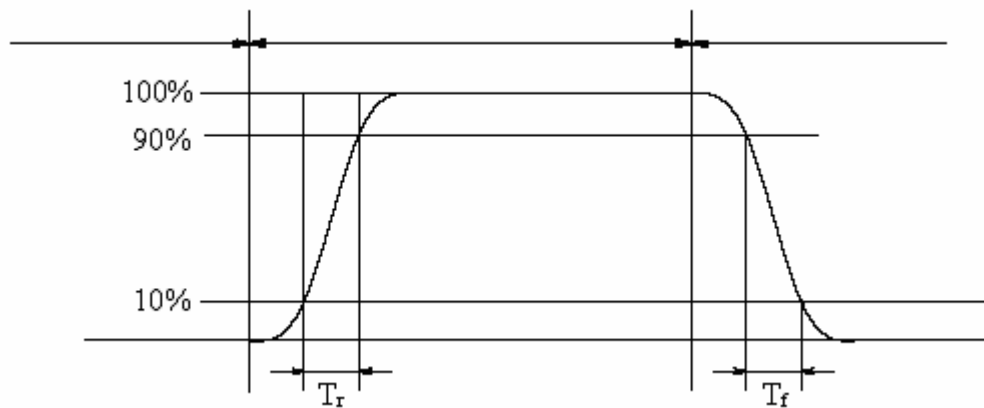

The definition of response time



Note 6: Definition of Color of CIE Coordinate and NTSC Ratio.

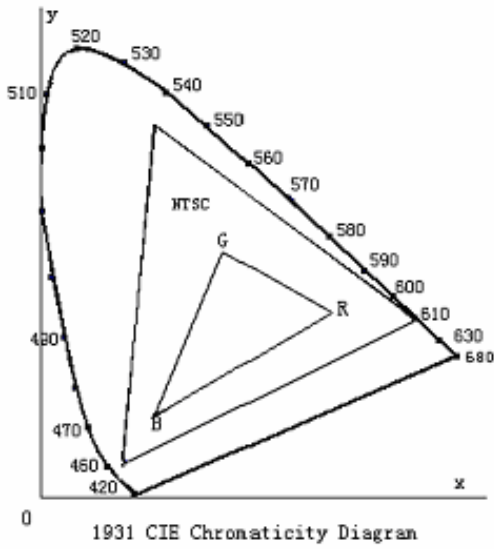

Color gamut:

$$S = \frac{\text{area of RGB triangle}}{\text{area of NTSC triangle}} \times 100\%$$



8.Initial Code Setting

```
void main_init()
{
    write_cmd(0x11); //defb 0x11, 0xff //sleepout

    delays(100);

    write_cmd(0xfe); //defb 0xfe, 0xfa //????

    delays(100);

    write_cmd(0x3a); //defb 0x3a, 0x05, 0xff //set_pixel_format
    write_index(0x05); //D3 "0" (Not Used) 101" =16 bit/pixel

    write_cmd(0x26); //defb 0x26, 0x02, 0xff //GAMSET (Gamma Set)
    write_index(0x02); //02h GC1 Gamma Curve 2 共4条曲线选择

    write_cmd(0xf2); //defb 0xf2, 0x00, 0xff //Gamma Setting (Green)
    write_index(0x00); //0: Disable (Default)

    write_cmd(0xb1); //defb 0xb1, 0x0c, 0x14, 0xff //Frame Rate Control (In
        normal mode/Full colors)
    write_index(0x0c); //DIVA = 0x0c 12
    write_index(0x14); //VPA = 0x14 20 frame rate =72hz

    write_cmd(0xc0); //defb 0xc0, 0x0c, 0x05, 0xff //Power_Control1
    write_index(0x0c); //VRH = 0x0c GVDD= 4.20
    write_index(0x05); //VC = 0x05 VCI1=2.50

    write_cmd(0xc1); //defb 0xc1, 0x02, 0xff //Power_Control2
        // AVDD VCL VGH VGL

    write_index(0x02); //BT = 2 4.75 -2.45 5xVCI1 -3xVCI1

    write_cmd(0xc5); //defb 0xc5, 0x36, 0x3b, 0xff //VCOM_Control 1
```



```
write_index(0x36); //VMH=54 VCOMH = 3.850

write_index(0x3B); //VML=59 VCOML = -1.025

write_cmd(0xc7); //defb 0xc7,0x40,0xff //VCOM Offset Control

write_index(0x40); //VMF = 64 VCOMH Output = "VMH"
                  VCOML Output Level = "VML"

write_cmd(0x2a); //defb 0x2a,0x00,0x00,0x00,0x7f,0xff //Column Address Set

write_index(0x00); //XS=0

write_index(0x00);

write_index(0x00); //XE=0x7f = 127

write_index(0x7F);
write_cmd(0x2b); //defb 0x2b,0x00,0x00,0x00,0x9f,0xff //Page Address Set

write_index(0x00); //YS=0

write_index(0x00);

write_index(0x00); //YE=0x9f 159

write_index(0x9F);
write_cmd(0x36); //defb 0x36,0x00,0xff //Memory Access Control
write_index(0xc8); //MY MX MV ML RGB MH
write_cmd(0x29); //defb 0x29,0xff //set_display_on
write_cmd(0x2c); //defb 0x2c,0xff

}
```

**9. Reliability Test Items and Criteria**

No	Test Item	Test condition	Criterion
1	High Temperature Storage	80°C±2°C 96H Restore 2H at 25°C Power off	The test result shall be evaluated after the sample has been left at room temperature and humidity for 2 hours without load. No condensation shall be accepted. The sample shall be free from defects: 1.Air bubble in the LCD; 2.Sealleak; 3.Non-display; 4.missing segments; 5.Glass crack;
2	Low Temperature Storage	-30°C±2°C 96H Restore 2H at 25°C Power off	
3	High Temperature Operation	70°C±2°C 96H Restore 2H at 25°C Power on	
4	Low Temperature Operation	-20°C±2°C 96H Restore 4H at 25°C Power on	
5	High Temperature & Humidity Operation	60°C±2°C 90%RH 96H Power on	
6	Temperature Cycle	-30°C→25°C→80°C 30min 5 min 30min after 10cycle, Restore 2H at 25°C	
7	Vibration Test	10Hz~150Hz, 100m/s ² , 120min	
8	Shock Test	Half-sine wave,300m/s	
9	Drop Test(package state)	800mm, concrete floor,1corner,	
10	ESD Sensitivity test	Contact ±4KV , 150PF/330 , 20times Air ±8KV,150PF/330 , 20times	

NOTE:

- 1.The test samples should be applied to only one test item.
- 2.Sample size for each test item is 5~10pcs.
- 3.For Damp Proof Test, Pure water(Resistance> 10MΩ) should be used.
- 4.In case of malfunction defect caused by ESD damage, if it would be recovered to normal state after resetting, it would be judge as a good part. Using ionizer(an antistatic blower) is recommended at working area in order to reduce electro-static voltage. When removing protection film from LCM panel, peel off the tag slowly(recommended more than one

second) while blowing with ionizer toward the peeling face to minimize ESD which may damage electrical circuit.

5. EL evaluation should be excepted from reliability test with humidity and temperature: Some defects such as black spot/blemish can happen by natural chemical reaction with humidity and Fluorescence EL has.

6. Polarizer test criteria

a. when testing avoid samples take out then return, It can cause water coagulation in Polarizer. Increase the distance of samples , And put samples before the wind.

b. When the samples are put into the test, put them upright so that the glasses keep spaces between them each other. (

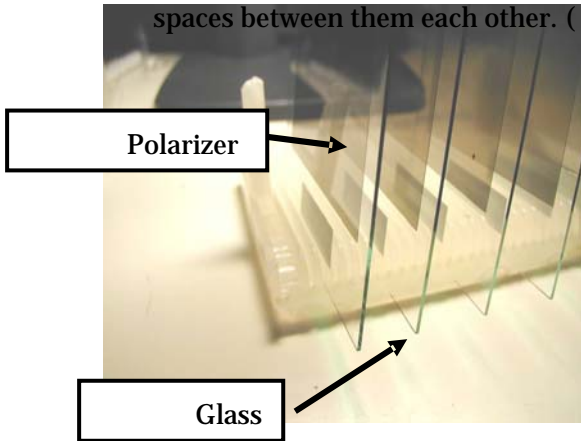

Picture 9.1

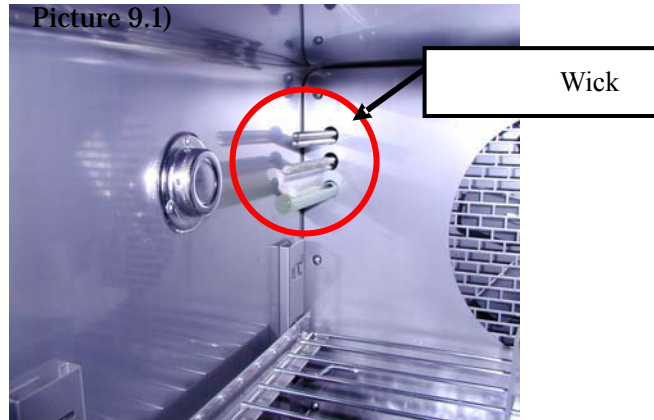

Picture 9.2

c. Put samples into testing machine as small as possible so that it is drafty.

d. Do not put samples under wick because water will fall.(Picture 9.2)

e. Do not open testing machine except for taking them out in order to prevent moisture condensation.

7.Please use automatic switch menu(or roll menu) testing mode when test operating mode

8.The inspection terms after reliability test, as below

ITEM	Inspection standard
Contrast	CR>50%
IDD	IDD<200%
Brightness	Brightness>60%
Color Tone	Color Tone+/-0.05

10 Quality level

10.1 Classification of defects

Major defects (MA): A major defect refers to a defect that may substantially degrade usability for product applications, including all functional defects(such as no display,abnormaldisplay, open or missin segment,short circuit,missing component), outline dimension beyond the drawing, progressive defects and those affecting reliability.

Minor defects (MI): A minor defect refers to a defect which is not considered to be able to substantially degrade the product application or a defect that deviates from existing standards almost unrelated to the effective use of the product or its operation, such as black spot, white spot, bright spot, pinhole, black line, white line, contrast variation, glass defect, polarizer defect, etc.

10.2 Definition of inspection range

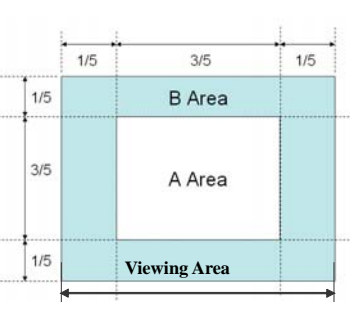
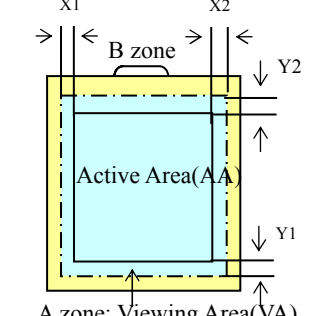
<p>For dot defect of TFT LCD which is not smaller than 3 inches, dividing three areas to make a judgment (according to figure 1). A area : center of viewing area B area : periphery of viewing area C area : Outside viewing area For other defects, dividing two areas to make a judgment (according figure 2). A zone : Inside Viewing area B zone : Outside Viewing area X1(A.A~V.A): mm X2(A.A~V.A): mm Y1(A.A~V.A): mm Y2(A.A~V.A): mm</p>	 <p style="text-align: center;">Figure 1</p>  <p style="text-align: center;">Figure 2</p>
--	--

10.3 Inspection items and general notes

<p>General notes</p>	<p>①Should any defects which are not specified in this standard happen, additional standard shall be determined by mutual agreement between customer and FORMIKE ②Viewing area should be the area which FORMIKE guarantees. ③Limit sample should be prior to this Inspection standard. ④Viewing judgment should be under static pattern. ⑤Inspection conditions Inspection distance: 250 mm (from the sample) Temperature : 25±5 °C Inspection angle : 45 degrees in 6 o'clock direction (all defects in viewing area should be inspected from this direction)</p>	
<p>Inspection items</p>	<p>Pinhole, Bright spot, Black spot, White spot, Black line, White Line, Foreign particle, Bubble</p>	<p>The color of a small area is different from the remainder. The phenomenon doesn't change with voltage</p>
	<p>Contrast variation</p>	<p>The color of a small area is different from the remainder. The phenomenon changes with voltage</p>
	<p>Polarizer defect</p>	<p>Scratch, Dirt, Particle, Bubble on polarizer or between polarizer and glass</p>
	<p>Dot defect (TFT LCD)</p>	<p>The pixel appears bright or dark abnormally when display</p>



Functional defect	No display, Abnormal display, Open or missing segment, Short circuit, False viewing direction
Glass defect	Glass crack, Shaved corner of glass, Surplus glass
PCB defect	Components assembly defect

10.4 Outgoing Inspection level

Outgoing Inspection standard	Inspection conditions	Inspection				
		Min.	Max.	Unit	IL	AQL
Major Defects	See 8.3 general notes	See 8.5			II	0.65
Minor Defects	See 8.3 general notes	See 8.5			II	1.5

Note: Sampling standard conforms to GB2828

10.5 Inspection Items and Criteria

Inspection items			Judgment standard			
			Category		Acceptable number	
					A zone	B zone
1	Black spot, White spot, Bright Spot, Pinhole, Foreign Particle, Particle in or on glass, Scratch on glass	$\Phi=(a+b)/2(m)$	A	$\Phi \leq 0.10$	Neglected	
			B	$0.10 < \Phi \leq 0.15$	2	
			C	$0.15 < \Phi \leq 0.20$	1	
			D	$0.20 < \Phi$	0	
			Total defective point(B,C)			3
2	Black line, White line, and Particle Between Polarizer and glass, Scratch on glass	 W: Width L: Length(mm)	A	$W \leq 0.01$	Neglected	
			B	$0.01 < W \leq 0.03$ $L \leq 3.0$	2	
			C	$0.03 < W \leq 0.05$ $L \leq 3.0$	1	
			D	$0.05 < W$	0	
			Total defective point(B,C)			3
3	Contrast variation	 $\Phi=(a+b)/2(mm)$	A	$\Phi \leq 0.2$	Neglected	
			B	$0.2 < \Phi \leq 0.3$	2	
			C	$0.3 < \Phi \leq 0.4$	1	
			D	$0.4 < \Phi$	0	
			Total defective point(B,C)			3

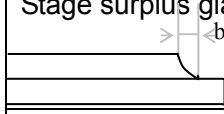
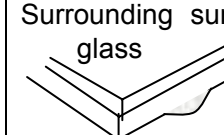

4	Dot defect (if TFT LCD is used)	TFT LCD is smaller than 3 inches	LCD Class	Defect	A area		B area
		TFT LCD between 3~10.4 inches	B	Bright dot	2		Neglected
				Dark dot	3		
				Total	4		
LCD Class	Defect	A area	B area	C area			
B	Bright dot	2	2	Neglected			
	Dark dot	2	3				
	Total	6					
Notes: Bright dot: in R、G、B or dark display figure, the pixel appears bright. Dark dot: in R、G、B or white display figure, the pixel appears dark. Defect area must be less than an half size of the dot.							
5	Bubble inside cell	any size		None	none		
6	Polarizer defect (if Polarizer is used)	Scratch ,damage on polarizer, Particle on polarizer or between polarizer and glass.	Refer to item 1 and item 2.				
		Bubble, dent and convex	A	$\Phi \leq 0.3$	Neglected		Neglected
			B	$0.3 < \Phi \leq 0.7$	2		
			C	$0.7 < \Phi$	0		
7	Surplus glass	Stage surplus glass 	$b \leq 0.3\text{mm}$				
		Surrounding surplus glass 	Should not influence outline dimension and assembling.				
8	Open segment or open common	Not permitted					
9	Short circuit	Not permitted					
10	False viewing direction	Not permitted					
11	Contrast ratio uneven	According to the limit specimen					
12	Crosstalk	According to the limit specimen					
13	Black /White spot(display)	Refer to item 1					
14	Black /White line(display)	Refer to item 2					

Inspection items		Judgment standard		Acceptable number			
		Category(application: B zone)					
15	Glass defect crack	①The front of lead terminals	A	$a \leq t, b \leq 1/5W, c \leq 3\text{mm}$	Max.3 defects allowed		
			B	Crack at two sides of lead terminals should not cover patterns and alignment mark			
			②Surrounding crack—non-contact side	<p>Inner border line of the seal Outer border line of the seal</p>		$b < \text{Inner border line of the seal}$	
			③ Surrounding crack— contact side	<p>Inner border line of the seal Outer border line of the seal</p>		$b < \text{Outer border line of the seal}$	
		④Corner	A	$a \leq t, b \leq 3.0, c \leq 3.0$			
			B	Glass crack should not cover patterns u and alignment mark and patterns.			

Inspection items		Judgment standard	
		Category(application: B zone)	
16	PCB defect	<p>Component soldering: No cold soldering、short、 open circuit、 burr、 tin ball The flat encapsulation component position deviation must be less than 1/3 width of the pin (Pic.1); the sheet component deviation: Pin deviates from the pad and contact with the near components is not permitted (Pic.2)</p>	<p>Component</p>
		<p>lead defect: The lead lack must be less than 1/3 of its width; The lead burr must be less than 1/3 of the seam; Impurities connect with the near leads is not permitted</p>	
		<p>Connector soldering: Soldering tin is at contact position of the plug and socket is not permitted No foundation is scald Serious cave distortion on plug and socket contact pin is not permitted</p>	
		<p>Glue on root of the speaker receiver and motor lead: The insulative coat of the lead must join into the PCB; the protected glue must envelop to the insulative coat.</p>	



11. Package Method

模块出货包装示意图：

