



FORMIKE ELECTRONIC CO.,LTD

PRDUCT SPECIFICATON

TFT LCD MODULE

MODEL : KWH018GM07-F01

【 】 Preliminary Specification

【 ♦ 】 Finally Specification

CUSTOMER'S APPROVAL	
SIGNATURE:	DATE:

APPROVED BY	PM REVIEWD	PD REVIEWD	PREPARED BY
Kam	/	Stephen	Roy

Prepared By :

FORMIKE ELECTRONIC CO.,LTD

Address :Room A818 New Energy Building, NanHai Road, NanShan District, ShenZhen, China. 518054

TEL:(86) 755 88306921,88306931 FAX:(86) 755 88304615

Http:// www.wandisplay.com

- This specification is subject to change withouth notice.Please contact FORMIKE or it's representative before designing your product based on this specification.

Issued Date: June - 20 -2008

Specification of LCD Module

Product No.: KWH018GM07-F01

Issue date: 2008/5/29



TABLE OF CONTENTS

1. GENERAL DESCRIPTION.....	4
2. FEATURES	4
3. MECHANICAL SPECIFICATION	4
4. MECHANICAL DIMENSION	5
5. DRIVER & CONTROLLER IC MAXIMUM RATINGS.....	6
6. ELECTRICAL CHARACTERISTIC.....	6
6.1. Backlight Dc Characteristics	7
7. FPC PIN DESCRIPTION.....	8
8. ELECTRO-OPTICAL CHARACTERISTICS	9
9. RELIABILITY	11
9.1. MTTF	11
9.2. Tests.....	11
9.3. Color Performance	11
10. INSPECTION CRITERIA.....	12
10.1. Inspection Conditions.....	12
10.2. Light Method	12
10.3. Classification Of Defects.....	13
10.4. Sampling & Acceptable Quality Level	13
10.5. Definition Of Inspection Area	13
10.6. Items and Criteria.....	14
11. ROHS COMPLIANT WARRANTY	15
12. PRECAUTIONS FOR USE.....	15
12.1. Safety.....	16
12.2. Storage Conditions	16



12.3. Installing LCD Module 17
12.4. Precautions For Operation17
12.5. Handling Precautions18
12.6. Warranty18

14. REVISION HISTORY19



1. GENERAL DESCRIPTION

The KWH018GM07-F01 model is a Color TFT LCD supplied by FORMIKE . This main Module has an 1.8 inch diagonally measured active display area with 128 X RGB X 160 resolution. Each pixel is divided into Red, Green and Blue sub-pixels and dots that are arranged in vertical stripes. LCD color is determined with Dithering 65K Color signal for each pixel.

The KWH018GM07-F01 has been designed to apply the interface method that enables low power, high speed, and high contrast.

2. FEATURES

Display Mode	TFT module Transmissive and Normally white type
Display Format	RGB Stripe
Color	65K/262K color
Input Data	80 series Parallel 8 bit
Viewing Direction	12 O'clock
Backlight	White LED*2
Driver IC	SPFD54124C

3. MECHANICAL SPECIFICATION

Item	Specifications	Unit
Dimensional outline	33.9(W)×45.6(H)×2.8(D)	mm
Resolution	128 X RGB × 160	Pixel
Active area	28.032(W)×35.04(H)	mm
Pixel pitch	0.219(W)×0.219(H)	mm
Dots pitch	0.073(W)×0.219(H)	mm

※Without FPC

※1 pixel = 3 dots = Red dot +Green dot +Blue dot



4. MECHANICAL DIMENSION

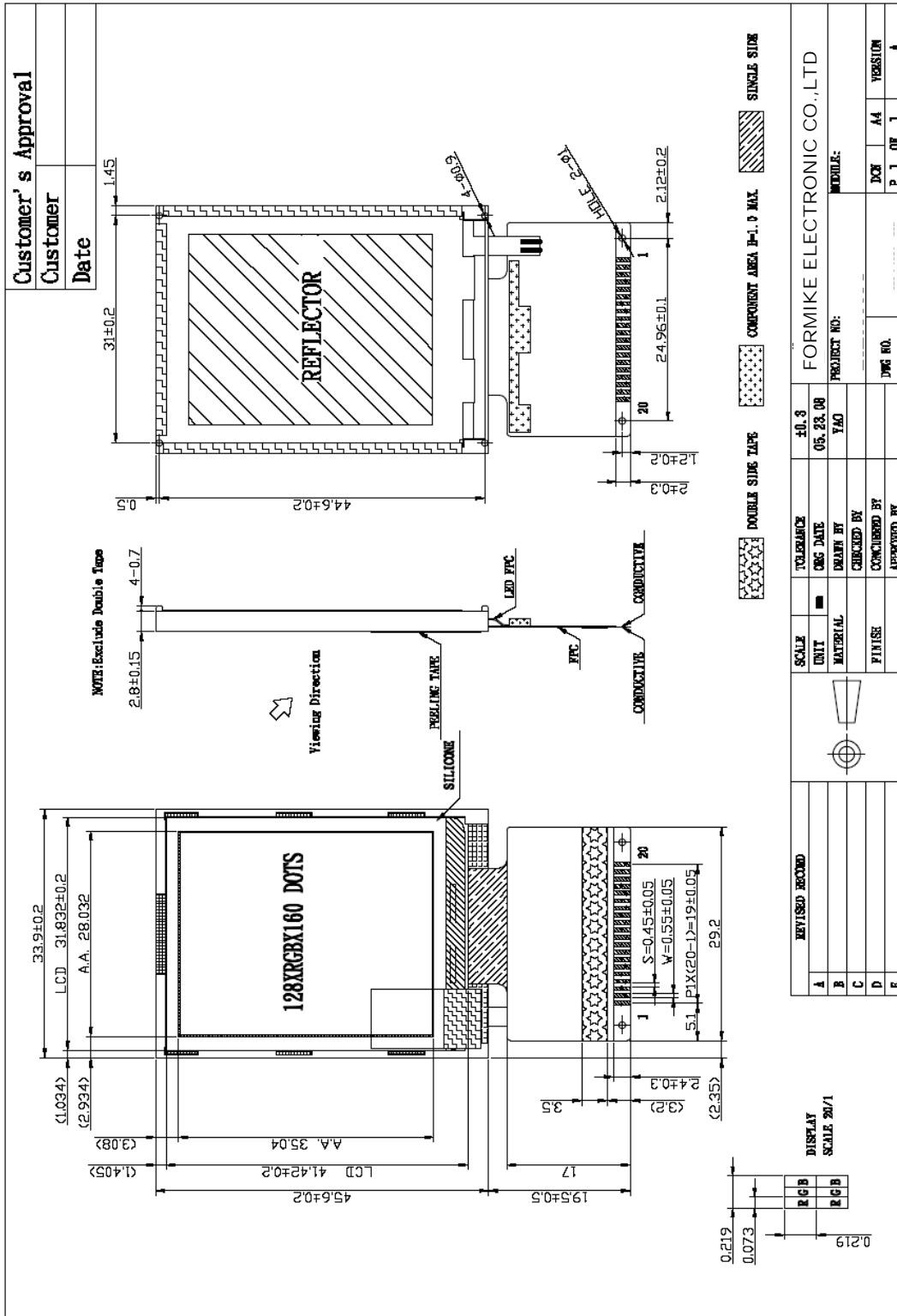



5. DRIVER & CONTROLLER IC MAXIMUM RATINGS

ITEM	SYMBOL	Min	Typ	Max	Units	Remark
Supply voltage	VDD	-0.3	-	+4.6	V	
Driver Supply voltage	VGH-VGL	-0.3	-	+30.0	V	
Input voltage range	V_t	-0.3	-	VDD+0.3	V	
Operating Temperature	T _{OP}	-20	-	70	°C	
Storage Temperature	T _{ST}	-30	-	80	°C	
Humidity	-	-	90	%RH	Note1	Humidity

Note1: $T_A \leq 40^\circ\text{C}$ Without dewing

6. ELECTRICAL CHARACTERISTIC

ITEM	SYMBOL	CONDITION	Min	Typ	Max	Units
Supply for Logic	V _{DD}	T _a = 25°C	2.5	2.78	3.6	V
Supply Current for LCM	I _{DD}	V _{DD} =2.85V (Full Black Pattern)	-	1.62	3.24	mA
Low Level Input Voltage	V _{il}	T _a = 25°C	GND	-	0.3 x V _{DD}	V
High Level Input Voltage	V _{ih}	T _a = 25°C	0.7 x V _{DD}	-	V _{DD}	V
Low Level Output Voltage	V _{ol}	T _a = 25°C	GND	-	0.2 x V _{DD}	V
High Level Output Voltage	V _{oh}	T _a = 25°C	0.8 x V _{DD}	-	V _{DD}	V

6.1.Backlight Dc Characteristics

ITEM	SYMBOL	CONDITION	Min	Typ	Max	Units
Backlight power supply	V_{LED}	$T_a = 25^{\circ}C$ $I = 20mA$	---	6.6	6.8	V
Backlight current	I_{LED}	$T_a = 25^{\circ}C$	---	20	---	mA

★ 1 Backlight LED Circuit :

2 CHIPS WHITE LED IN SERIES

★2 Uniform measure condition :

(a)Measure 9 point. Measure location is show below :

(b)Uniform = (Min. brightness / Max. brightness) \times 100%

(c)Best Contrast, Main and sub panel All dots turn ON (White screen)

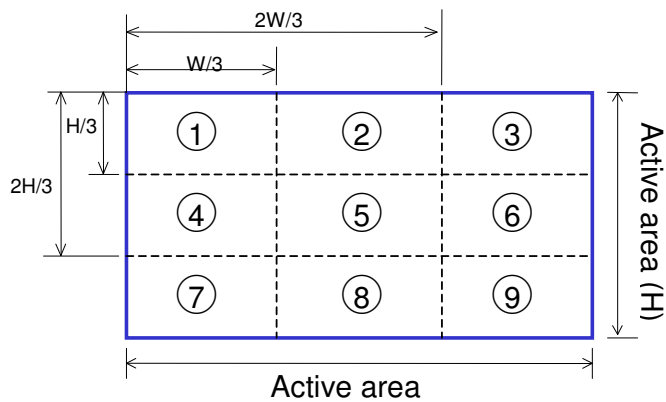



7. FPC PIN DESCRIPTION

NO	SYMBOL	Description
1	BL_K	Backlight cathode Logic power supply voltage
2	BL_A	Backlight common anode
3	GND	Ground
4	VDD	Logic power supply voltage
5	NC	No connect
6	NC	No connect
7	/CS	LCD Chip select
8	/RESET	RESET Signal input
9	RS	Data/Command control Pin
10	/WR	Write execution control Pin
11	/RD	Read execution control Pin
12	DB7	Date Bus 7
13	DB6	Date Bus 6
14	DB5	Date Bus 5
15	DB4	Date Bus 4
16	DB3	Date Bus 3
17	DB2	Date Bus 2
18	DB1	Date Bus 1
19	DB0	Date Bus 0
20	GND	Ground



8. ELECTRO-OPTICAL CHARACTERISTICS

Parameter		Symbol	Min.	Typ.	Max.	Units	Note
Luminance of white		Lwh	180	220	-	cd/m ²	● Note 4
Contrast Ratio		CR	210	300	-	-	● Note 1
CIE color Coordinates	White	Wx	(0.27)	(0.31)	(0.35)	-	● BM7; 2° angle
		Wy	(0.30)	(0.34)	(0.38)		
	Red	Rx	(0.58)	(0.62)	(0.66)		
		Ry	(0.32)	(0.36)	(0.40)		
	Green	Gx	(0.29)	(0.33)	(0.37)		
		Gy	(0.54)	(0.58)	(0.62)		
	Blue	Bx	(0.10)	(0.14)	(0.18)		
By		(0.09)	(0.11)	(0.15)			
Color Gamut (NTSC)		S (%)	-	51	-	%	● Note 5
Response Time	Ring+Falling	Tr+Tf	-	30	-	ms	○ Note 3
Viewing Angle (with Polarizer)	X axis right ($\psi=0^\circ$)	θ_x	-	60	-	degree	○ Note 2
	X axis left ($\psi=180^\circ$)	θ_x	-	60	-		
	Y axis up ($\psi=90^\circ$)	θ_y	-	60	-		
	Y axis down ($\psi=270^\circ$)	θ_y	-	50	-		

● For LCM

NOTE 1: Definition of contrast ratio:

Measure contrast ratio on the below 5 points and take average value ◦

Contrast ratio is calculated with the following formula:

$$\text{Contrast Ratio (CR)} = (\text{White}) \text{ Luminance of ON} \div (\text{Black}) \text{ Luminance of OFF}$$

NOTE 2: Definition of Viewing Angle (θ , Ψ)

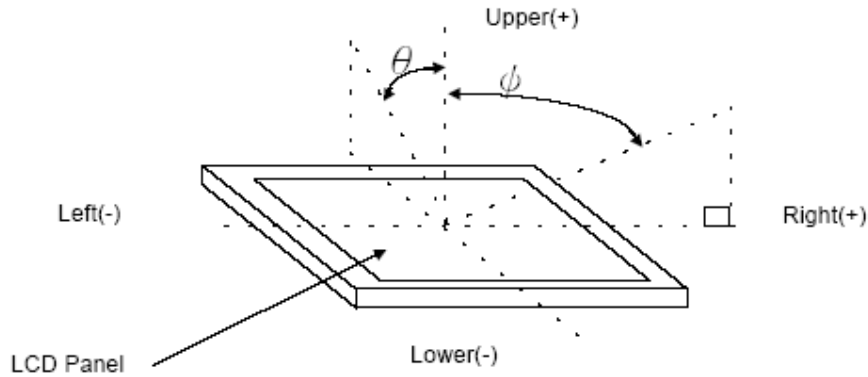

NOTE 3: Definition of Response Time

The response time is defined as the time interval between the 10% and 90% amplitudes ◦

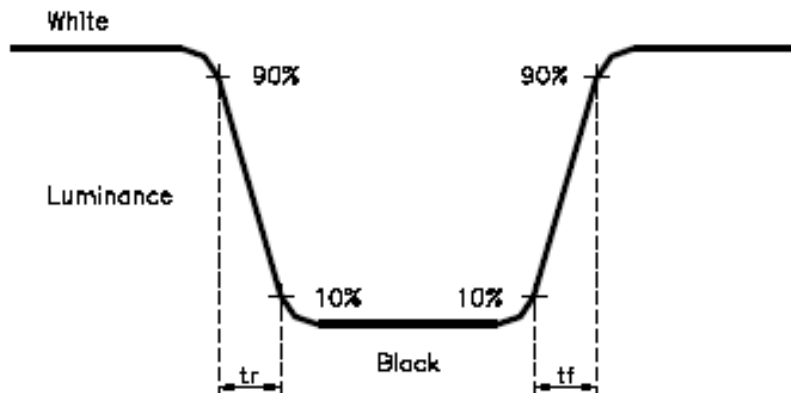

NOTE 4:

To be measured at the center area of panel with a viewing cone of 2° by Topcon luminance meter BM-7, after 10 minutes operation (module)

NOTE 5: The definition of Color Gamut

$$\text{Color Gamut : } S(\%) = (\text{RGB Triangle Area} / \text{NTSC Triangle Area}) \times 100$$



9. RELIABILITY

9.1.MTTF

The LCD module shall be designed to meet a minimum MTTF value of 50,000 hours with normal condition. (25°C in the room without sunlight; not include life time of backlight)

9.2. Tests

NO.	ITEM	CONDITION	CRITERION
1	High Temperature Operating	70°C 240hrs	<ul style="list-style-type: none"> ◦ No defect of operational function in room temperature are allowable(23±5°C). ◦ Leakage current should be below double of initial value.
2	Low Temperature Operating	-20°C 240 hrs	
3	High Temperature Non-Operating	80°C 240 hrs	
4	Low Temperature Non-Operating	-30°C 240 hrs	
5	High Temperature/ Humidity Non-Operating	50°C ,90%RH 240 hrs	
6	Temperature Shock Non-Operating	-30°C ←→ 80°C (30min) (5min) (30min) 10 CYCLES	
7	Electro-static Discharge	HBM: ±2kv	

Note 1: Test after 24 hours in room temperature(23±5°C).

Note 2: The sampling above is individually for each reliability testing condition.

Note 3: The color fading of polarizing filter should not care.

Note 4: All of the reliability testing chamber above, is using D.I. water.(Min value:1.0 MΩ-cm)

Note 5: In case of malfunction defect caused by ESD damage, if it would be recovered to normal state after resetting, it would be judged as a good part.

9.3.Color Performance

No.	ITEM	Criterion (initial)
1	Luminance	>50%
2	NTSC	>70%
3	Contrast Ratio	>50%

10.INSPECTION CRITERIA

10.1.Inspection Conditions

10.1.1.Environmental conditions

The environmental conditions for inspection shall be as follows

Room temperature: $23\pm 5^{\circ}\text{C}$

Humidity: $50\pm 20\%RH$

10.1.2.The external visual inspection

With a single $1000\pm 200\text{lux}$ fluorescent lamp as the light source, the inspection was in the distance of 30cm or more from the LCD to the inspector's eyes.

10.2.Light Method

10.2.1.Environment lamp under $1000\pm 200\text{ lux}$, Viewing direction for inspection over 30 cm

10.2.2.The distance from eye to defect around 300mm, the distance from ND Filter to defect around 25~30mm

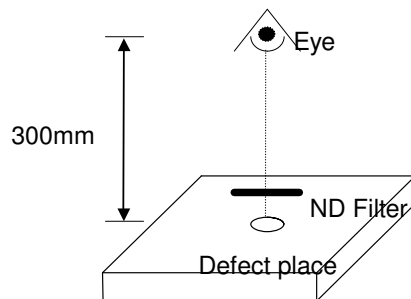



10.3.Classification Of Defects

10.3.1.Major defect

A major defect refers to a defect that may substantially degrade usability for product applications.

10.3.2.Minor defect

A minor defect refers to a defect which is not considered to be able substantially degrade the product application or a defect that deviates from existing standards almost unrelated to the effective use of the product or its operation.

Notes: If the LCD/LCM 's cosmetic and display performance do not specify in "inspection criterion", it should be based on these delivered samples.

10.4.Sampling & Acceptable Quality Level

Level II, MIL-STD-105E

	Major	Minor
Cosmetic	1.0 %	1.5 %
Electrical-display	0.4%	0.65 %

10.5.Definition Of Inspection Area

V.A: Viewing Area

A.A: Active Area

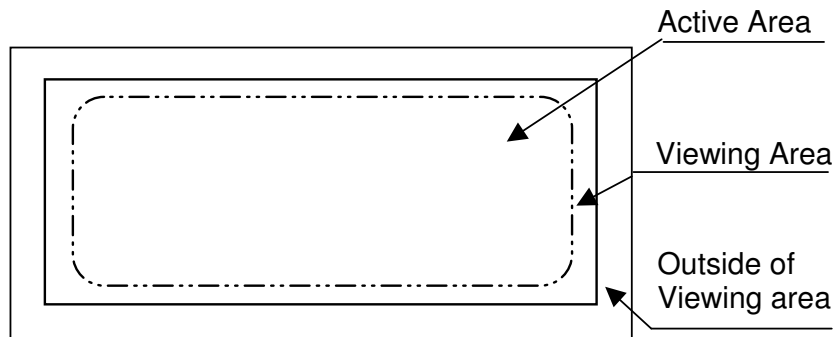

10.6.Items and Criteria

10.6.1.Visual inspection criterion in cosmetic

(1) Glass defect

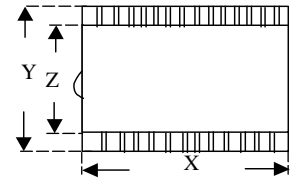
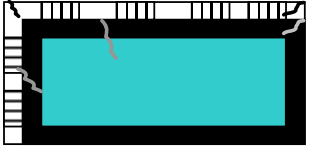
Glass defect			
No	Defect	Criteria	Remark
1	Dimension (Minor)	By engineering diagram	
2	Cracks (Major)	Extensive crack 【Reject】	

(2) LCM appearance defect

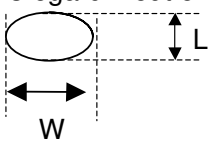
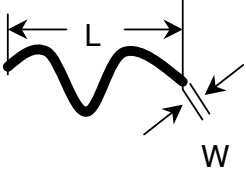
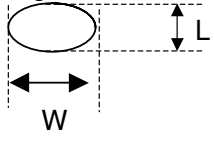
No	Defect	Criteria	Permissible Qty	Remark
1	Round type (Minor)	Spec.	Permissible Qty	1. $\phi = (L+W)/2$, L: Length, W: Width 2. Disregard if out of A.A. 
		$\phi \leq 0.10\text{mm}$	Disregard	
		$0.10\text{mm} < \phi \leq 0.20\text{mm}$	3	
		$0.20\text{mm} < \phi$	0	
2	Line type (Minor)	Spec.	Permissible Qty	1. L: Length, W: Width 2. Disregard if out of A.A. 
		$W \leq 0.03\text{mm}$	Disregard	
		$L \leq 3.0\text{mm}$ and $0.03\text{mm} < W \leq 0.05\text{mm}$	2	
		$L \leq 3.0\text{mm}$ and $0.05\text{mm} < W \leq 0.10\text{mm}$	1	
		$W > 0.10\text{mm}$ or $L > 3.0\text{mm}$	0	
3	Polarizer dent (Minor)	Spec.	Permissible Qty	1. $\phi = (L+W)/2$, L: Length, W: Width 2. Disregard if out of A.A. 
		$\phi \leq 0.20\text{mm}$	Disregard	
		$0.20\text{mm} < \phi \leq 0.30\text{mm}$	2	
		$0.30\text{mm} < \phi \leq 0.50\text{mm}$	1	
		$0.50\text{mm} < \phi$	0	



(3) FPC

No	Defect	Criteria	Remark
1	Copper peeling (Minor)	Copper peeling 【Reject】	

(4) Black tape

No	Defect	Criteria	Remark
1	Shift (Minor)	IC exposed 【Reject】	
2	No black tape (Minor)	No black tape 【Reject】	

(5) Silicon

No	Defect	Criteria	Remark
1	Amount of silicon (Minor)	ITO exposed 【Reject】	

10.6.2. Visual inspection criterion in electrical display

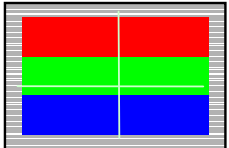
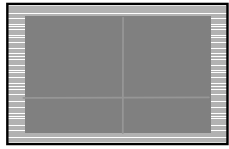
No	Defect	Criteria		Remark
1	No display (Major)	Not allowed		
2	Missing line (Major)	Not allowed		
3	Darker or lighter line (Major)	Not allowed		
4	Weak line (Minor)	By limited sample		
5	Bright / Dark point (Minor)	Spec.	Permissible Qty	1:1 sub-pixel: 1R or 1G or 1B 2:Point defect area \geq 1/2 sub pixel.
		Bright point	1	
		Dark point	2	

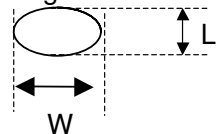
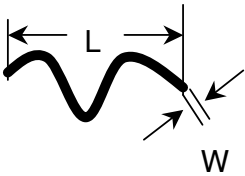

No	Defect	Criteria		Remark
6	Round type (Minor)	Spec.	Permissible Qty	1. $\phi = (L+W)/2$, L: Length, W: Width 2. Disregard if out of A.A. 
		$\phi \leq 0.10\text{mm}$	Disregard	
		$0.10\text{mm} < \phi \leq 0.20\text{mm}$	3	
		$0.20\text{mm} < \phi$	0	
7	Line type (Minor)	Spec.	Permissible Qty	1. L: Length, W: Width 2. Disregard if out of A.A. 
		$W \leq 0.03\text{mm}$	Disregard	
		$L \leq 3.0\text{mm}$ and $0.03\text{mm} < W \leq 0.05\text{mm}$	2	
		$L \leq 3.0\text{mm}$ and $0.05\text{mm} < W \leq 0.10\text{mm}$	1	
		$W > 0.10\text{mm}$ or $L > 3.0\text{mm}$	0	
8	Mura (Minor)	By 5% ND filter invisible		

10.6.3.Others

1. Issues that are not defined in this document shall be discussed and agreed with both parties. (Customer and supplier)
2. Unless otherwise agreed upon in writing, the criteria shall be applied to both parties. (Customer and supplier)



13. RoHS COMPLIANT WARRANTY

RoHS Hazardous substances including:

- Cd < 100 ppm
- Pb < 1000 ppm
- Hg < 1000 ppm
- Cr +6 < 1000 ppm
- PBDE < 1000 ppm
- PBB < 1000 ppm

14. PRECAUTIONS FOR USE

14.1. Safety

- (1) Do not swallow any liquid crystal, even if there is no proof that liquid crystal is poisonous.
- (2) If the LCD panel breaks, be careful not to get liquid crystal to touch your skin.
- (3) If skin is exposed to liquid crystal, wash the area thoroughly with alcohol or soap.

14.2. Storage Conditions

- (1) Store the panel or module in a dark place where the temperature is $23\pm 5^{\circ}\text{C}$ and the humidity is below $50\pm 20\%\text{RH}$.
- (2) Store in anti-static electricity container.
- (3) Store in clean environment, free from dust, active gas, and solvent.
- (4) Do not place the module near organics solvents or corrosive gases.
- (5) Do not crush, shake, or jolt the module.
- (6) Do not exposed to direct sun light of fluorescent lamps.

14.3. Installing LCD Module

Attend to the following items when installing the LCM.

- (1) Cover the surface with a transparent protective plate or touch panel to protect the polarizer and LC cell.
- (2) When assembling the LCM into other equipment, the spacer to the bit between the LCM and the fitting plate should have enough height to avoid causing stress to the module surface, refer to the individual specifications for measurements. The measurement tolerance should be $\pm 0.1\text{mm}$.



14.4.Precautions For Operation

- (1) Viewing angle varies with the change of liquid crystal driving voltage (V_o). Adjust V_o to show the best contrast.
- (2) Driving the LCD in the voltage above the limit will shorten its lifetime.
- (3) Response time is greatly delayed at temperature below the operating temperature range. However, this does not mean the LCD will be out of the order. It will recover when it returns to the specified temperature range.
- (4) When turning the power on, input each signal after the positive/negative voltage becomes stable.
- (5) Do not apply water or any liquid on product which composed of T/P.

14.5.Handling Precautions

- (1) Avoid static electricity which can damage the CMOS LSI; please wear the wrist strap when handling.
- (2) The polarizing plate of the display is very fragile. so, please handle it very carefully.
- (3) Do not give external shock.
- (4) Do not apply excessive force on the surface; it may cause display abnormal .
- (5) Do not wipe the polarizing plate with a dry cloth, as it may easily scratch the surface of plate.
- (6) Do not use ketonics solvent & Aromatic solvent, use with a soft cloth soaked with a cleaning naphtha solvent.
- (7) Do not operate it above the absolute maximum rating.
- (8) Do not remove the panel or frame from the module.
- (9) Do not apply water or any liquid on product, which composed of T/P.

14.6.Warranty

- (1) The period is within 12 months since the date of shipping out under normal using and storage conditions.
- (2) The warranty will be avoided in case of defect induced by customer.

14.REVISION HISTORY

Version	Revise record	Date
A	New version	2008/6/20